

NATIONAL TELECOMMUNICATIONS AGENCY

RESOLUTION N° 238, NOVEMBER 9 2000

[Approving the Regulation for Certifying
Telecommunication Equipment Electrical Safety
Aspects](#)

THE DIRECTING BOARD OF THE NATIONAL TELECOMMUNICATIONS AGENCY –ANATEL- through the attributions granted it under Art. 22 of Law N° 9,472, of July 16 1997, and Art. 35 of the National Telecommunications Agency Regulations, approved by Decree N° 2.338, of October 7 1997,

WHEREAS the comments received pursuant to Public Consultation N° 210 of January 26 2000, published in the Diário Oficial da União on January 26 2000;

WHEREAS the deliberation reached in Meeting N° 138 on November 1 2000, decides to:

Art. 1st Approve the Regulation for Certifying Telecommunication Equipment Electrical Safety Aspects, as attached to this Resolution.

Sole Paragraph. This Regulation will only become effective after six months from its publication.

Art. 2nd This Resolution enters in force on the date of its publication.

LUIZ FRANCISCO TENÓRIO PERRONE

Acting Chairman of the Board

**REGULATION FOR CERTIFYING TELECOMMUNICATION
EQUIPMENT ELECTRICAL SAFETY ASPECTS**

TITLE I
GENERAL PROVISIONS

Chapter I
Purpose

Art. 1st This Regulation is intended to establish the electrical safety requirements to be met by telecommunication products, complementing the specific regulations on these products, for their certification by the National Telecommunications Agency - Anatel.

Chapter II
References

Art. 2nd The following references apply to this Regulation:

I – Anatel – Regulation on Certifying and Approving Telecommunication Products

II - IEC 60950 (1999) - Safety of Information Technology Equipment.

III - IEC 651 (1979) - Sound Level Meters.

IV - ITU-T Rec. K.21 (1996) - Resistibility of Subscriber's Terminal to Overvoltage and Overcurrents.

V - ITU-T Rec. P.36 (1988) - Efficiency of Devices for Preventing the Occurrence of Excessive Acoustic Pressure by Telephone Receivers.

Chapter III
Scope

Art. 3rd This Regulation applies to all Category I Telecommunication Products and those Category II Telecommunication Products intended for installation at the user's environment as defined in the specific regulation mentioned in sub I of Art 2nd.

§ 1st The Requirements on Preventing Excessive Acoustic Pressure, described in TITLE II of this Regulation, are applicable to Category I and II Telecommunication Products fitted with acoustic outputs, as described in the aforementioned reference.

§ 2nd The Requirements on Preventing Fire Hazard, described in TITLE III of this Regulation, are applicable to Category I Telecommunication Products connected to the external telecommunication network through conductors.

§ 3rd The Requirements on Preventing Electrical Shock, described in TITLE IV of this Regulation,

are applicable to Category I and II Telecommunication Products connected to the external telecommunication network through conductors and/or powered through the electric mains, as described in the aforementioned reference.

§ 4th The Requirements on Preventing Excessive Heating, described in TITLE V of this Regulation, are applicable to all Category I and II Telecommunication Products, as described in the aforementioned reference.

Chapter IV Definitions

Art. 4th The following definitions apply for the purpose of this Regulation::

I – Equipment to Be Certified – ESC: telecommunication equipment to undergo the testing prescribed in Regulation for its certification.

II – Electromagnetic Disturbance: electromagnetic phenomenon capable of degrading the performance of a device, equipment or system, or to adversely affect living or inanimate matter.

III – Terminal: equipment or apparatus providing the user with access to public interest telecommunication service.

IV – User: any party employing public interest telecommunication service, regardless the existence of a service provisioning contract or subscription taken out with the Provider.

V – Subscriber: a person or firm contacting for service from a Provider.

VI – Network Termination Point – PTR: a physical connecting point from the External Network to the Subscriber's Internal Network providing individual access to the POTS, intended for general public use.

VII – External Network: stretch of the Telecommunications Network supporting the POTS running from the Network Termination Point – PTR inclusive, to the Main Distribution Frame in a Central Office.

VIII – Subscriber's Internal Network: stretch of the Telecommunications Network supporting POTS intended for general public use, starting at the premises indicated by the subscriber for general public use POTS availability and running to the PTR, exclusive.

IX – Grounding Terminal: telecommunication equipment terminal for providing the electrical connection to a building's grounding system.

X – Electrical Power Terminals: locally powered telecommunication equipment terminals through which the electrical power required for the referred equipment operation is provided.

XI – Telecommunication Terminals: telecommunication equipment terminals over which the information flows and, in the case of remotely powered equipment, the electrical power required for its operation is sent.

XII – dBA: acoustic pressure unit of measure corresponding to 20 times the logarithm to base 10 of the ratio between an acoustic pressure, calculated or measured with weight A, and the reference acoustic pressure. In this Regulation, the value assigned to acoustic pressure is 20 Pa.

XIII – Weighting A: the weight at 1000 Hz relative frequency with values as given in the document mentioned in sub III of Art 2nd.

Chapter V Applying the Regulation

Art. 5th The following conditions should be met when applying this Regulation:

I – The quantity of equipment making up the sample to be tested, the quantity of terminals to be tested per equipment and the configuration of the equipment to be tested should meet the Anatel regulation on the applicable certification rules.

II – The requirements of this Regulation should be verified with the equipment to be certified placed in a climate-controlled environment that provides a room temperature of $(25\pm 3)^{\circ}\text{C}$ and a relative air humidity of $(60\pm 10)\%$.

TITLE II PROTECTION FROM ACOUSTICAL SHOCK

Chapter I Requirements for Protection from Acoustical Shock

Art. 6th When operating normally or subjected to transient electromagnetic disturbance at its terminals, the equipment to be certified should not give rise to transient acoustic pressure exceeding 135 dBA peak relative to 20 Pa.

§1st When simulating the normal operation of the equipment to be certified, operations that may give rise to acoustical pulses should be verified.

§2nd When simulating transient electromagnetic disturbance, the telecommunication terminals should be submitted to disturbance with a 10/700 s waveform and peak voltage of 1.5 kV, as defined in sub IV of Art 2nd.

Art. 7th When operating normally or subjected to permanent electromagnetic disturbance at its terminals, the equipment to be certified should not give rise to permanent acoustic pressure exceeding 125 dBA, relative to 20 Pa, as defined in sub XII of Art. 4th.

§1st When simulating the normal operation of the equipment to be certified, the conditions under which the equipment may generate tones should be checked, complying with the following:

I – tones or other signals restricted to 0.5 s should be considered transient, according to the criteria provided in Art. 6th;

II – repeated signals, such as generated by automatic tone sending, should be considered as permanent signals, according to the aforementioned criteria. In this case, set the sound meter to an

average reading;

§2nd When simulating permanent electromagnetic disturbance at the telecommunication terminals connected to the external network, the equipment to be certified should be submitted to a (1000 ± 20) Hz frequency, 10 V_{rms} amplitude sine wave voltage.

Chapter II Conditions for Verifying Requirements

Art. 8th For verifying the requirements on protecting from acoustic shock, the equipment to be certified should be set to its normal operating condition, as follows:

I – activate the equipment so as to circulate the normal link current;

II – in applicable equipment, the earphone should be installed on an artificial ear that meets the requirements given in the document referred to in sub V of Art. 2nd;

III – in applicable equipment, the artificial ear should be connected to a sound level meter. This meter should comply with the document referred to in sub III of Art. 2nd and be prepared for measuring values with the A-weighting defined in sub XIII of Art. 4th.

TITLE III PROTECTION FROM FIRE HAZARD

Chapter I Requirements for Protection from Fire Hazard

Art. 9th When submitted to the application of a 230 V_{rms} (60 Hz) voltage for 15 minutes between a telecommunication terminal corresponding to the external network and the grounding terminal, the equipment to be certified should not present fire hazard.

§1st Fire hazard is assessed visually, attested by flames appearing in the equipment when running the test, as described in the document referred to in sub IV of Art. 2nd.

§2nd For applying the test voltage, a generator with the following characteristics should be utilized:

I – open circuit voltage of 230 V_{rms};

II – sine wave shape at a 60 Hz frequency;

III – short circuit current on each line as per Table 1.

Table 1: Short circuit currents for testing fire hazard.

0.23 A	0.38 A	0.72 A	1.4 A	2.9 A	5.75 A	11.5 A	23 A
--------	--------	--------	-------	-------	--------	--------	------

Note: Each generator line (line a and line b) should provide measured short circuit current figures according to Table 1.

Chapter II Conditions for Verifying the Requirements

Art. 10. For verifying fire protection requirements, the equipment to be certified should be placed in its normal operating position, not necessarily powered, under the following conditions:

I – lines on the same terminal should be tested at the same time, as shown in Figure 1 (TITLE VI – Annexes);

II – the generator's short circuit current should be set to the smallest value given in Table 1 and the test run under this condition;

III – if the test run has no hazard of fire, the generator's short circuit current should be set to the next higher value and the test repeated, successively, under fire hazard appears or the maximum current specified in Table 1 is reached.

§1st If a grounding terminal is not available, the equipment should be placed on a metal sheet, used as grounding.

§2nd The test should be repeated under open and closed link conditions.

TITLE IV PROTECTION FROM ELECTRICAL SHOCK

Chapter I Requirements for Protection from Electrical Shock

Art. 11. With the equipment to be certified powered under normal conditions (rated voltage), all its accessible parts should present a leakage current of less than $0.25 \text{ mA}_{\text{rms}}$.

Art. 12. At a 60 Hz frequency for 1 minute, the application of overvoltages at the terminals of the equipment to be certified should give rise to leakage currents on its accessible parts of less than 5 mA_{rms}. The following overvoltages should be applied:

I - $500 \text{ V}_{\text{rms}}$ overvoltage on the telecommunication terminals;

II - $1,500 \text{ V}_{\text{rms}}$ overvoltage on the electrical power terminals.

Chapter II Conditions for Verifying the Requirements

Art. 13. When measuring the leakage current specified in Art. 11, the following conditions should be met:

I – check all metal parts with the artificial finger referred to in sub II of Art. 2nd. The artificial finger should check all outer equipment metal parts, as well as be inserted in equipment openings, in order to check accessible inner metal parts;

II – check all equipment outer surfaces, both metallic and non-metallic, utilizing a 20 cm by 10 cm

oblong-shaped flexible metal sheet (this sheet is intended to simulate the human hand);

III – the leakage current should be measured according to the circuit of Figure 2;

IV – the test setup should comply with Figures 3a or 3b, for AC or DC powered equipment, respectively.

Art. 14 When measuring the leakage current specified in Art. 12, the following conditions should be met:

I – the equipment to be certified should be wrapped in a flexible metal sheet, in order to ensure that this sheet touches all outer metal parts accessible to human beings;

II – the test voltage should be applied between this sheet and the equipment's terminals, as described in Figure 4, Title VI.

TITLE V PROTECTION FROM OVER HEATING

Chapter I Requirement for Protection from Over Heating

Art. 15. The increase in temperature over the room temperature at any human-accessible outer part of the equipment to be certified should not exceed the limits provided in Table 2.

Table 2 – Limits on temperature increase over room temperature.

	Metal Surface	Non-Metal Surface
Parts frequently touched	30°C	40°C
Parts eventually touched	45°C	55°C

Chapter II Conditions for Verifying the Requirements

Art. 16. For measuring the temperature specified in Art 15, the following conditions should be met:

I – the equipment should be powered at a voltage 6% above its rated value until its temperature stabilizes;

II – the equipment's surface and room temperature should be measured. The figures given in Table 2 correspond to the difference between a surface temperature and the room temperature.

TITLE VI
ANNEXES

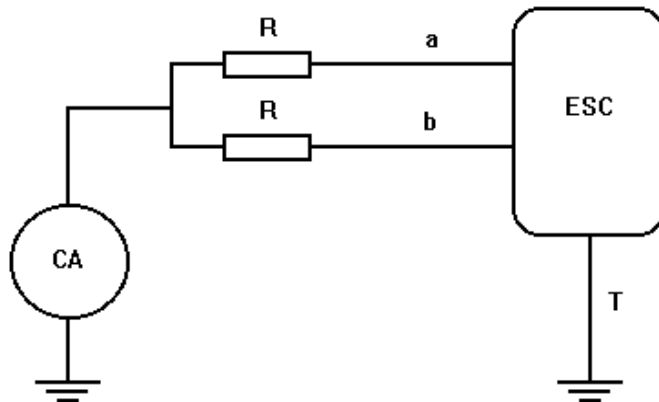

ESC = Equipment to be certified
 T = Grounding terminal or metal plate
 R = Resistances to be adjusted for obtaining short circuit currents
 CA = Alternating power supply

Figure 1 – Test Setup for Verifying Fire Hazard.

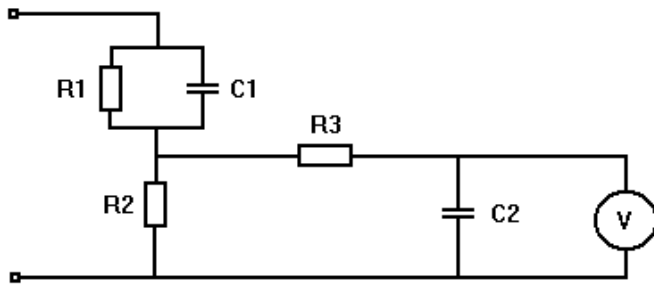

$R1 = 1500\ \Omega$ $R2 = 500\ \Omega$ $k\ \Omega$ $R3 = 10$
 $C1 = 220\ nF$ $C2 = 22\ nF$
 V = True rms reading voltmeter (input resistance $\geq 1\ M\Omega$ and input capacitance $\leq 200\ pF$)

The weighted leakage current in milliamperes (mA) is given by $2U$, where U is the voltage figure obtained through the voltmeter in Volts

Figure 2 – Circuit for Measuring Working Voltage Leakage Currents

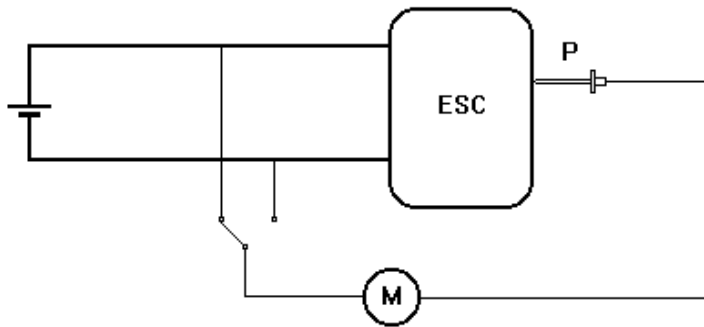

M = Leakage current meter (see Figure 2)

P = Artificial finger and/or hand

TI = Insulating transformer

CA = Alternating power supply

ESC = Equipment to be certified

Figure 3a – Setup for Measuring Working Voltage Leakage Current (AC powered).

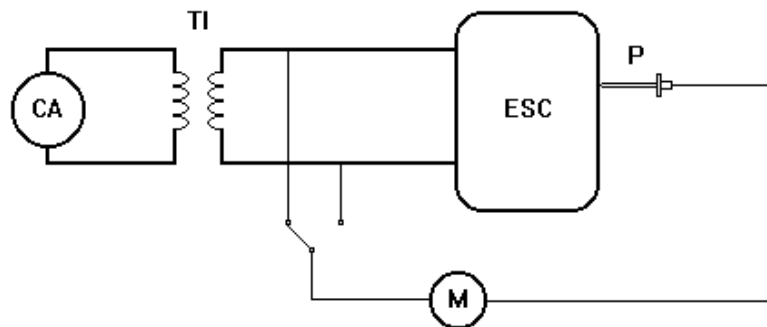

M = Leakage current meter (see Figure 2)

P = Artificial finger and/or hand

ESC = Equipment to be certified

Figure 3b - Setup for Measuring Working Voltage Leakage Current (DC powered)

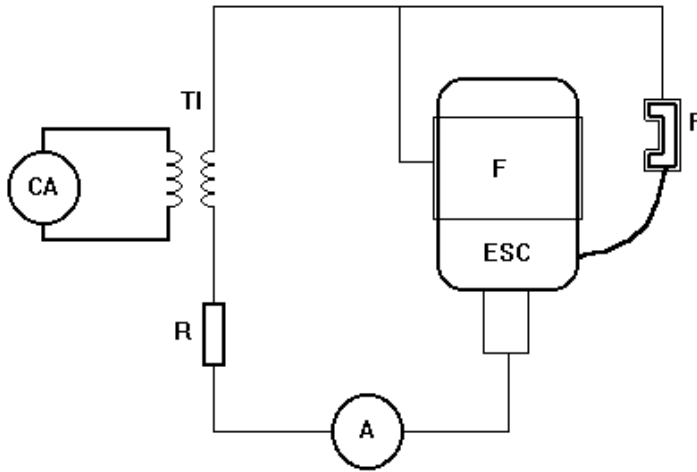

- CA = Alternating voltage source
- TI = Insulating transformer
- ESC = Equipment to be certified
- R = 10 k Ω (leakage current limiting resistance)
- A = Ammeter
- F = Metal sheet in contact with the ESC's exposed parts

Figure 4 – Setup for Measuring Overvoltage Leakage Current