



INTERNATIONAL TELECOMMUNICATION UNION

ITU-T

TELECOMMUNICATION
STANDARDIZATION SECTOR
OF ITU

G.992.5

(05/2003)

SERIES G: TRANSMISSION SYSTEMS AND MEDIA,
DIGITAL SYSTEMS AND NETWORKS

Digital sections and digital line system – Access networks

**Asymmetric Digital Subscriber Line (ADSL)
transceivers – Extended bandwidth ADSL2
(ADSL2+)**

ITU-T Recommendation G.992.5

ITU-T G-SERIES RECOMMENDATIONS
TRANSMISSION SYSTEMS AND MEDIA, DIGITAL SYSTEMS AND NETWORKS

INTERNATIONAL TELEPHONE CONNECTIONS AND CIRCUITS	G.100–G.199
GENERAL CHARACTERISTICS COMMON TO ALL ANALOGUE CARRIER-TRANSMISSION SYSTEMS	G.200–G.299
INDIVIDUAL CHARACTERISTICS OF INTERNATIONAL CARRIER TELEPHONE SYSTEMS ON METALLIC LINES	G.300–G.399
GENERAL CHARACTERISTICS OF INTERNATIONAL CARRIER TELEPHONE SYSTEMS ON RADIO-RELAY OR SATELLITE LINKS AND INTERCONNECTION WITH METALLIC LINES	G.400–G.449
COORDINATION OF RADIOTELEPHONY AND LINE TELEPHONY TESTING EQUIPMENTS	G.450–G.499
TRANSMISSION MEDIA CHARACTERISTICS	G.500–G.599
DIGITAL TERMINAL EQUIPMENTS	G.600–G.699
DIGITAL NETWORKS	G.700–G.799
DIGITAL SECTIONS AND DIGITAL LINE SYSTEM	G.800–G.899
General	G.900–G.909
Parameters for optical fibre cable systems	G.910–G.919
Digital sections at hierarchical bit rates based on a bit rate of 2048 kbit/s	G.920–G.929
Digital line transmission systems on cable at non-hierarchical bit rates	G.930–G.939
Digital line systems provided by FDM transmission bearers	G.940–G.949
Digital line systems	G.950–G.959
Digital section and digital transmission systems for customer access to ISDN	G.960–G.969
Optical fibre submarine cable systems	G.970–G.979
Optical line systems for local and access networks	G.980–G.989
Access networks	G.990–G.999
QUALITY OF SERVICE AND PERFORMANCE - GENERIC AND USER-RELATED ASPECTS	G.1000–G.1999
TRANSMISSION MEDIA CHARACTERISTICS	G.6000–G.6999
DIGITAL TERMINAL EQUIPMENTS	G.7000–G.7999
DIGITAL NETWORKS	G.8000–G.8999

For further details, please refer to the list of ITU-T Recommendations.

ITU-T Recommendation G.992.5

Asymmetric Digital Subscriber Line (ADSL) transceivers – Extended bandwidth ADSL2 (ADSL2+)

Summary

This Recommendation describes Asymmetrical Digital Subscriber Line (ADSL) transceivers on a metallic twisted pair that allows high-speed data transmission between the network operator end (ATU-C) and the customer end (ATU-R), using extended bandwidth. This Recommendation defines a variety of frame bearers in conjunction with one of two other services or without underlying service, dependent on the environment:

- 1) ADSL transmission simultaneously on the same pair with voiceband service;
- 2) ADSL transmission simultaneously on the same pair with ISDN (see Appendix I or II/G.961 [1]) services;
- 3) ADSL transmission without underlying service, optimized for deployment with ADSL over voiceband service in the same binder cable.

ADSL transmission on the same pair with voiceband services and operating in an environment with TCM-ISDN (see Appendix III/G.961 [1]) services in an adjacent pair, is for further study.

ADSL transmission without underlying service, optimized for deployment with ADSL over ISDN service in the same binder cable, is for further study.

ADSL transmission with extended upstream bandwidth, simultaneously on the same pair with voiceband service, is for further study.

This Recommendation specifies the physical layer characteristics of the extended bandwidth Asymmetrical Digital Subscriber Line (ADSL) interface to metallic loops. As compared to the ADSL2 transceiver defined in ITU-T Rec. G.992.3 [5], the operating modes use double the downstream bandwidth. When operating on the same pair with voice band services, an additional operating mode is defined, also using the double upstream bandwidth.

This Recommendation has been written to help ensure the proper interfacing and interworking of ADSL transmission units at the customer end (ATU-R) and at the network operator end (ATU-C) and also to define the transport capability of the units. Proper operation shall be ensured when these two units are manufactured and provided independently. A single twisted pair of telephone wires is used to connect the ATU-C to the ATU-R. The ADSL transmission units must deal with a variety of wire pair characteristics and typical impairments (e.g., crosstalk and noise).

An extended bandwidth ADSL transmission unit (ADSL2+ transceiver) can simultaneously convey all of the following: a number of downstream frame bearers, a number of upstream frame bearers, a baseband POTS/ISDN duplex channel, and ADSL line overhead for framing, error control, operations, and maintenance. Systems support a net data rate ranging up to a minimum of 16 Mbit/s downstream and 800 kbit/s upstream. Support of net data rates above 16 Mbit/s downstream and support of net data rates above 800 kbit/s upstream are optional.

This Recommendation includes mandatory requirements, recommendations and options; these are designated by the words shall, "should" and "may" respectively. The word "will" is used only to designate events that take place under some defined set of circumstances. This Recommendation is written as a delta Recommendation relative to ITU-T Rec. G.992.3. For the clauses which have been changed, this Recommendation contains complete replacement text (unless explicitly indicated). For the clauses which have not been changed, this Recommendation contains only the clause heading, with reference to ITU-T Rec. G.992.3.

This Recommendation defines several optional capabilities and features:

- transport of STM and/or ATM and/or packets;
- transport of a network timing reference;
- multiple latency paths;
- multiple frame bearers;
- short initialization procedure;
- dynamic rate repartitioning;
- seamless rate adaptation.

It is the intention of this Recommendation to provide, by negotiation during initialization, for U-interface compatibility and interoperability between transceivers complying with this Recommendation and between transceivers that include different combinations of options.

History

This Recommendation describes extended bandwidth ADSL2 (ADSL2+) transceivers, as a delta to the second generation ADSL (ADSL2 – ITU-T Rec. G.992.3).

This Recommendation has been written to provide additional features, relative to ITU-T Rec. G.992.3. ITU-T Rec. G.992.3 was approved on the 29 of July 2002. Several potential improvements have been identified to better address higher data rates for shorter loops and longer reach for high data rates. This Recommendation provides a new ADSL U-interface specification, including the identified improvements, which the ITU-T believes will be most helpful to the ADSL industry.

Relative to ITU-T Rec. G.992.3, the following application-related feature has been added:

- Improved support for services requiring high downstream data rates (e.g., broadband entertainment services).

Relative to ITU-T Rec. G.992.3, the following PMS-TC-related feature has been added:

- Support of up to 3 Reed-Solomon codewords per symbol;

Relative to ITU-T Rec. G.992.3, the following PMD-related features have been added:

- Extended downstream bandwidth to 2.208 MHz (512 subcarriers) for all operation modes (POTS/ISDN/All Digital Mode);
- Downstream spectrum control with individual maximum transmit PSD at U-C reference point per subcarrier, under operator control through CO-MIB, allows configuration per the regional requirements (e.g., North America, Europe or Japan) and deployment scenarios (e.g., CO or Remote).
- Downstream spectrum shaping during Showtime (shaped transmit PSD in the passband, i.e., non-flat) for improved downstream transmit PSD flexibility.

Through negotiation during initialization, the capability of equipment to support the G.992.5 and other G.992.x ADSL Recommendations is identified. For reasons of interoperability, equipment may choose to support multiple Recommendations, such that it is able to adapt to the operating mode supported by the far-end equipment.

Source

ITU-T Recommendation G.992.5 was approved by ITU-T Study Group 15 (2001-2004) under the ITU-T Recommendation A.8 procedure on 22 May 2003.

FOREWORD

The International Telecommunication Union (ITU) is the United Nations specialized agency in the field of telecommunications. The ITU Telecommunication Standardization Sector (ITU-T) is a permanent organ of ITU. ITU-T is responsible for studying technical, operating and tariff questions and issuing Recommendations on them with a view to standardizing telecommunications on a worldwide basis.

The World Telecommunication Standardization Assembly (WTSA), which meets every four years, establishes the topics for study by the ITU-T study groups which, in turn, produce Recommendations on these topics.

The approval of ITU-T Recommendations is covered by the procedure laid down in WTSA Resolution 1.

In some areas of information technology which fall within ITU-T's purview, the necessary standards are prepared on a collaborative basis with ISO and IEC.

NOTE

In this Recommendation, the expression "Administration" is used for conciseness to indicate both a telecommunication administration and a recognized operating agency.

Compliance with this Recommendation is voluntary. However, the Recommendation may contain certain mandatory provisions (to ensure e.g. interoperability or applicability) and compliance with the Recommendation is achieved when all of these mandatory provisions are met. The words "shall" or some other obligatory language such as "must" and the negative equivalents are used to express requirements. The use of such words does not suggest that compliance with the Recommendation is required of any party.

INTELLECTUAL PROPERTY RIGHTS

ITU draws attention to the possibility that the practice or implementation of this Recommendation may involve the use of a claimed Intellectual Property Right. ITU takes no position concerning the evidence, validity or applicability of claimed Intellectual Property Rights, whether asserted by ITU members or others outside of the Recommendation development process.

As of the date of approval of this Recommendation, ITU had not received notice of intellectual property, protected by patents, which may be required to implement this Recommendation. However, implementors are cautioned that this may not represent the latest information and are therefore strongly urged to consult the TSB patent database.

© ITU 2004

All rights reserved. No part of this publication may be reproduced, by any means whatsoever, without the prior written permission of ITU.

CONTENTS

	Page
1 Scope	1
2 References.....	2
3 Definitions	3
4 Abbreviations.....	3
5 Reference Models	3
6 Transport Protocol Specific Transmission Convergence (TPS-TC) function	3
7 Physical Media Specific Transmission Convergence (PMS-TC) function	3
7.1 Transport capabilities	3
7.2 Additional functions	3
7.3 Block interface signals and primitives	3
7.4 Block diagram and internal reference point signals	3
7.5 Control parameters	3
7.6 Frame structure	3
7.7 Data plane procedures	4
7.8 Control plane procedures.....	5
7.9 Management plane procedures	5
7.10 Initialization procedures	5
7.11 On-line reconfiguration	5
7.12 Power management mode.....	5
8 Physical Media Dependent function.....	5
8.1 Transport capabilities	5
8.2 Additional functions	5
8.3 Block interface signals and primitives	5
8.4 Block diagram and internal reference point signals	5
8.5 Control parameters	5
8.6 Constellation encoder for data symbols	14
8.7 Constellation encoder for synchronization and L2 exit symbols	14
8.8 Modulation	14
8.9 Transmitter dynamic range.....	16
8.10 Transmitter spectral masks	16
8.11 Control plane procedures.....	17
8.12 Management plane procedures	17
8.13 Initialization procedures	17
8.14 Short initialization procedures.....	32
8.15 Loop diagnostics mode procedures	37

	Page
8.16 On-line reconfiguration of the PMD function	45
8.17 Power management in the PMD function	45
9 Management Protocol Specific Transmission Convergence (MPS-TC) functions	45
9.1 Transport functions.....	45
9.2 Additional functions	45
9.3 Block interface signals and primitives	46
9.4 Management plane procedures	46
9.5 Power management	52
10 Dynamic behaviour.....	53
Annex A – Specific requirements for an ADSL system operating in the frequency band above POTS.....	53
A.1 ATU-C functional characteristics (pertains to clause 8)	53
A.2 ATU-R functional characteristics (pertains to clause 8)	58
A.3 Initialization.....	62
A.4 Electrical characteristics.....	62
Annex B – Specific requirements for an ADSL system operating in the frequency band above ISDN as defined in ITU-T Rec. G.961 Appendices I and II.....	62
B.2 ATU-R functional characteristics (pertains to clause 8)	67
B.3 Initialization.....	71
B.4 Electrical characteristics.....	71
Annex C – Specific requirements for an ADSL system operating in the same cable as ISDN as defined in ITU-T Rec. G.961 Appendix III	71
Annex D – ATU-C and ATU-R state diagrams	71
Annex E – POTS and ISDN-BA splitters	71
Annex F – ATU-x performance requirements for Region A (North America)	71
F.1 Performance requirements for operation of ADSL over POTS (Annex A) ...	71
F.2 Performance requirements for operation of All Digital Mode ADSL (Annex I)	71
F.3 Performance requirements for operation of ADSL over POTS, with extended upstream bandwidth (Annex L)	72
Annex G – ATU-x performance requirements for Region B (Europe)	72
G.1 Performance requirements for operation of ADSL over POTS (Annex A) ...	72
G.2 Performance requirements for operation of ADSL over ISDN (Annex B)....	72
G.3 Performance requirements for operation of All Digital Mode ADSL (Annex I)	72
G.4 Performance requirements for operation of All Digital Mode ADSL (Annex J)	72

	Page
G.5 Performance requirements for operation of ADSL over POTS, with extended upstream bandwidth (Annex L)	72
Annex H – Specific requirements for a synchronized symmetrical DSL (SSDSL) system operating in the same cable binder as ISDN as defined in ITU-T Rec. G.961 Appendix III	72
Annex I – All Digital Mode ADSL with improved spectral compatibility with ADSL over POTS	72
I.1 ATU-C functional characteristics (pertains to clause 8)	72
I.2 ATU-R functional characteristics (pertains to clause 8)	76
I.3 Initialization.....	78
I.4 Electrical characteristics.....	78
Annex J – All Digital Mode ADSL with improved spectral compatibility with ADSL over ISDN.....	79
Annex K – TPS-TC functional descriptions	79
Annex L – Specific requirements for an ADSL system with extended upstream bandwidth, operating in the frequency band above POTS	79
Appendix I – ATM Layer to Physical Layer logical interface	79
Appendix II – Compatibility with other customer premises equipment.....	79
Appendix III – The impact of primary protection devices on line balance	79
Appendix IV – PSD template to be used in capacity calculations with in-band transmit spectrum shaping	80
Appendix V – Bibliography.....	81

ITU-T Recommendation G.992.5

Asymmetric Digital Subscriber Line (ADSL) transceivers – Extended bandwidth ADSL2 (ADSL2+)

1 Scope

For interrelationships of this Recommendation with other G.99x-series Recommendations, see Appendix IV – Bibliography [B1].

This Recommendation describes the interface between the telecommunications network and the customer installation in terms of their interaction and electrical characteristics. The requirements of this Recommendation apply to a single asymmetric digital subscriber line (ADSL).

ADSL provides a variety of frame bearers in conjunction with other services:

- ADSL service on the same pair with voiceband services (including POTS and voiceband data services). The ADSL service occupies a frequency band above the voiceband service, and is separated from it by filtering.
- ADSL service on the same pair as ISDN service, as defined in Appendices I and II/G.961 [1]. The ADSL service occupies a frequency band above the ISDN service, and is separated from it by filtering.

ADSL also provides a variety of frame bearers without baseband services (i.e., POTS or ISDN) being present on the same pair.

- ADSL service on a pair, with improved spectral compatibility with ADSL over POTS present on an adjacent pair.

In the direction from the network operator to the customer premises (i.e., the downstream direction), the frame bearers provided may include low-speed frame bearers and high-speed frame bearers; in the other direction from the customer premises to the central office (i.e., the upstream direction), only low-speed frame bearers are provided.

The transmission system is designed to operate on two-wire twisted metallic copper pairs with mixed gauges. This Recommendation is based on the use of copper pairs without loading coils, but bridged taps are acceptable in all but a few unusual situations.

Operation on the same pair with voiceband services (e.g., POTS and voiceband data services), and with TCM-ISDN service as defined in Appendix III/G.961 [1] on an adjacent pair, is for further study.

Operation without baseband service, with improved spectral compatibility with ADSL over ISDN present on an adjacent pair, is for further study.

Operation for the simultaneous transport of voiceband services and frame bearers on a single twisted-pair, with extended ADSL upstream bandwidth, is for further study.

An overview of digital subscriber line transceivers can be found in Appendix IV – Bibliography [B1].

Specifically, this Recommendation:

- defines the Transmission Protocol Specific Transmission Convergence Sub-layer for ATM, STM and Packet transport through the frame bearers provided;
- defines the combined options and ranges of the frame bearers provided;
- defines the line code and the spectral composition of the signals transmitted by both ATU-C and ATU-R;

- defines the initialization procedure for both the ATU-C and the ATU-R;
- specifies the transmit signals at both the ATU-C and ATU-R;
- describes the organization of transmitted and received data into frames;
- defines the functions of the OAM channel;

In separate annexes it also:

- describes the transmission technique used to support the simultaneous transport of voiceband services and frame bearers (ADSL over POTS, Annex A) on a single twisted-pair;
- describes the transmission technique used to support the simultaneous transport of ISDN services as defined in Appendices I and II/G.961 [1], and frame bearers (ADSL over ISDN, Annex B) on a single twisted-pair;
- describes the transmission technique used to support the transport of only frame bearers on a pair, with improved spectral compatibility with ADSL over POTS present on adjacent pair (All Digital Mode, Annex I).

This Recommendation defines the minimal set of requirements to provide satisfactory simultaneous transmission between the network and the customer interface of a variety of frame bearers and other services such as POTS or ISDN. This Recommendation permits network providers an expanded use of existing copper facilities. All required physical layer aspects to ensure compatibility between equipment in the network and equipment at a remote location are specified. Equipment may be implemented with additional functions and procedures.

2 References

The following ITU-T Recommendations and other references contain provisions which, through reference in this text, constitute provisions of this Recommendation. At the time of publication, the editions indicated were valid. All Recommendations and other references are subject to revision; users of this Recommendation are therefore encouraged to investigate the possibility of applying the most recent edition of the Recommendations and other references listed below. A list of the currently valid ITU-T Recommendations is regularly published. The reference to a document within this Recommendation does not give it, as a stand-alone document, the status of a Recommendation.

- [1] ITU-T Recommendation G.961 (1993), *Digital transmission system on metallic local lines for ISDN basic rate access*.
- [2] ITU-T Recommendation G.994.1 (2003), *Handshake procedures for digital subscriber line (DSL) transceivers*.
- [3] ITU-T Recommendation G.996.1 (2001), *Test procedures for digital subscriber line (DSL) transceivers*.
- [4] ITU-T Recommendation G.997.1 (2003), *Physical layer management for digital subscriber line (DSL) transceivers*.
- [5] ITU-T Recommendation G.992.3 (2002), *Asymmetric digital subscriber line (ADSL) transceivers 2 (ADSL2)*, plus Amendment 1 (2003).

For Annex B

- [6] ETSI TS 102 080 V1.3.2 (2000-05), *Transmission and Multiplexing (TM); Integrated Services Digital Network (ISDN) basic rate access; Digital transmission system on metallic local lines*.

3 Definitions

ITU-T Rec. G.992.3 defines terms applicable to this Recommendation.

4 Abbreviations

ITU-T Rec. G.992.3 defines abbreviations applicable to this Recommendation.

5 Reference Models

See clause 5/G.992.3.

This Recommendation provides tools for the operator of the access network to control the ADSL transmit PSD and aggregate power in the downstream and upstream directions. Depending on regional spectrum management guidelines, these tools may be needed to enable remote ADSL deployment. In this case, the ATU-C is located in a remote cabinet located between the central office and the customer premises, rather than the Access Node.

6 Transport Protocol Specific Transmission Convergence (TPS-TC) function

See clause 6/G.992.3.

7 Physical Media Specific Transmission Convergence (PMS-TC) function

See clause 7/G.992.3.

7.1 Transport capabilities

See 7.1/G.992.3.

7.2 Additional functions

See 7.2/G.992.3.

7.3 Block interface signals and primitives

See 7.3/G.992.3.

7.4 Block diagram and internal reference point signals

See 7.4/G.992.3.

7.5 Control parameters

See 7.5/G.992.3.

7.6 Frame structure

7.6.1 Derived definitions

See 7.6.1/G.992.3.

7.6.2 Valid framing configurations

Table 7-1 displays the allowable range of each PMS-TC control parameter. Additionally, the control parameters shall satisfy some relationships to one another for the set of control parameter values to be valid as displayed in Table 7-1. Some ranges of the valid control parameter values are expressed in terms of NSC, which is the number of subcarriers as defined in 8.8.1, Subcarriers.

An additional requirement is made on the value of the $B_{p,n}$. Each frame bearer shall be transported in one and only one latency path. This means that in any valid framing configuration, there shall be no more than one non-zero control parameter in each set $\{B_{0,n}, B_{1,n}, B_{2,n}, B_{3,n}\}$.

Table 7-1/G.992.5 – Valid framing configurations

Parameter	Capability
MSG_{min}	$4000 \leq MSG_{min} \leq 64000$
MSG_{max}	$MSG_{max} = 64000$
N_{BC}	$1 \leq N_{BC} \leq 4$
N_{LP}	$1 \leq N_{LP} \leq 4$
MSG_{LP}	$0 \leq MSG_{LP} \leq 3$
MSG_C	The valid values of MSG_C are those required to support valid minimum and maximum overhead rates, MSG_{min} and MSG_{max} .
$B_{p,n}$	$0 \leq B_{p,n} \leq 254, \sum_n B_{p,n} \leq 254$
M_p	1, 2, 4, 8 or 16. If $R_p = 0$ then $M_p = 1$
T_p	$1 \leq T_p \leq 64$
R_p	0, 2, 4, 6, 8, 10, 12, 14, or 16
D_p	1, 2, 4, 8, 16, 32, 64 if $R_p = 0$ then $D_p = 1$
L_p	$1 \leq L_p \leq 15 \times (NSC - 1)$ and $\sum L_p$ shall be such that $8 \leq \sum L_p \leq 15 \times (NSC - 1)$
Relation of S_p and M_p	Configurations that satisfy the following relationship are valid: $M_p / 3 \leq S_p \leq 32 \times M_p$ (see Note 1).
Overhead Rate Constraints	Configurations that satisfy the following relationship are valid: $0.8 \text{ kbit/s} \leq OR_p \leq 64 \text{ kbit/s}$ (see Note 2).
Delay Constraints	Configurations that satisfy the following relationship are valid: $1/3 \leq S_p \leq 64$ (see Note 3).
Overhead Channel Period	Configurations that provide a period for each overhead channel PER_p between 15 and 20 ms are valid.
NOTE 1 – This condition is a bound on the number of Mux Data Frames per symbol.	
NOTE 2 – The 0.8 kbit/s overhead rate lower bound corresponds to an $SEQ_p = 2$ (see Table 7-14/G.992.3) and an overhead channel period of 20 ms.	
NOTE 3 – This condition puts bounds on the number of FEC codewords per symbol.	

NOTE – The G.992.5 PMS-TC function differs from the G.992.3 PMS-TC function only in the upper bound of the number of Mux Data Frames per symbol and the number of FEC codewords per symbol. ITU-T Rec. G.992.5 defines an upper bound of three, while ITU-T Rec. G.992.3 defines an upper bound of two.

7.6.3 Mandatory configurations

See 7.6.3/G.992.3.

7.7 Data plane procedures

See 7.7/G.992.3.

7.8 Control plane procedures

See 7.8/G.992.3.

7.9 Management plane procedures

See 7.9/G.992.3.

7.10 Initialization procedures

See 7.10/G.992.3.

For use in this Recommendation, the unsigned 12-bit `net_max` value in Table 7-18/G.992.3 is the data rate divided by 8000 (rather than 4000 for use in ITU-T Rec. G.992.3).

7.11 On-line reconfiguration

See 7.11/G.992.3.

7.12 Power management mode

See 7.12/G.992.3.

8 Physical Media Dependent function

See clause 8/G.992.3.

8.1 Transport capabilities

See 8.1/G.992.3.

8.2 Additional functions

See 8.2/G.992.3.

8.3 Block interface signals and primitives

See 8.3/G.992.3.

8.4 Block diagram and internal reference point signals

See 8.4/G.992.3.

8.5 Control parameters

8.5.1 Definition of control parameters

The configuration of the PMD function is controlled by a set of control parameters defined in 8.5.1/G.992.3.

The tss_i values depend on CO-MIB settings (see ITU-T Rec. G.997.1 [4]) and on local capabilities and are exchanged in the G.994.1 Phase. The tss_i values are determined by the ATU transmit function:

- For the upstream direction, the CO-MIB settings consist of a per upstream subcarrier indication of which subcarriers may be in the upstream SUPPORTEDset and which subcarriers shall not be in the upstream SUPPORTEDset. This information is conveyed from ATU-C to ATU-R in the G.994.1 CL upstream spectrum shaping parameter block and is used by the ATU-R (in combination with local restrictions) to determine which subcarriers to include in the upstream SUPPORTEDset (see 8.13.2.4).

- For the downstream direction, the CO-MIB settings consist of a per downstream subcarrier indication of which subcarriers may be in the downstream SUPPORTEDset and which subcarriers shall not be in the downstream SUPPORTEDset. This information is used by the ATU-C (in combination with local restrictions) to determine which subcarriers to include in the downstream SUPPORTEDset (see 8.13.2.4).
- For the downstream direction, the CO-MIB settings also include the downstream PSD mask applicable at the U-C2 reference point (see clause 5). This MIB PSD mask may impose PSD restrictions in addition to the Limit PSD mask defined in the relevant Annex, as relevant for the chosen application option. This information is used by the ATU-C (in combination with local restrictions) to determine which subcarriers to include in the downstream SUPPORTEDset (see 8.13.2.4) and to determine the level of spectrum shaping (i.e., tss_i value) to be applied to these subcarriers. The downstream PSD mask specified through the CO-MIB shall satisfy the requirements defined in the remainder of this clause.

The downstream PSD mask in the CO-MIB shall be specified through a set of breakpoints. Each breakpoint shall consist of a subcarrier index t and a MIB PSD mask level (expressed in dBm/Hz) at that subcarrier. The set of breakpoints can then be represented as $[(t_1, PSD_1), (t_2, PSD_2), \dots, (t_N, PSD_N)]$. In the CO-MIB, the subcarrier index shall be coded as an unsigned integer in the range from $\text{roundup}(f_{pb_start}/\Delta f)$ to $\text{rounddown}(f_{pb_stop}/\Delta f)$, where f_{pb_start} and f_{pb_stop} are the lower and higher edge, of the passband respectively and Δf is the subcarrier spacing defined in 8.8.1. The passband is defined in Annexes A, B or I, as relevant to the selected application option. The MIB PSD mask level shall be coded as an unsigned integer representing the MIB PSD mask levels 0 dBm/Hz (coded as 0) to -127.5 dBm/Hz (coded as 255), in steps of 0.5 dBm/Hz, with valid range 0 to -95 dBm/Hz. The maximum number of breakpoints is 32.

The set of breakpoints specified in the CO-MIB shall comply to the following restrictions, and the corresponding MIB PSD mask for each frequency f shall be defined as following:

1) *General*

- $t_n < t_{n+1}$ for $n = 1$ to $N - 1$
- $f_n = t_n \times \Delta f$

2) *Low-frequency end and high-frequency end of MIB PSD mask (f)*

- $t_1 = \text{roundup}(f_{pb_start}/\Delta f)$ or $(75 \leq t_1 \leq 273)$
- $t_N = \text{rounddown}(f_{pb_stop}/\Delta f)$
- f_{lm_start} = frequency at which the flat extension below f_1 intersects the Limit mask (0 Hz if no intersect).
- f_{lm_stop} = frequency at which the flat extension above f_N intersects the Limit mask.
- At frequencies below f_1 and at frequencies above f_N , the MIB PSD mask shall be obtained as follows:

$$MIB\ PSD\ mask(f) = \begin{cases} Limit\ mask(f) & f < f_{lm_start} \\ PSD_1 & f_{lm_start} \leq f \leq f_1 \\ PSD_N & f_N < f \leq f_{lm_stop} \\ Limit\ mask(f) & f > f_{lm_stop} \end{cases}$$

3) *MIB PSD stopband in lower frequency part*

if $(75 \leq t_1 \leq 273)$ then:

- $PSD_1 = -95$ dBm/Hz
- Set of valid t_2 values is every 10th tone starting from tone 100 up until tone 280

- The value t_1 shall be:

$$t_1 = \text{rounddown} \left(t_2 - \left(\frac{PSD_2 - PSD_1}{2.2 \text{ dB/tone}} \right) \right)$$

- At frequencies between f_1 and f_2 , the MIB PSD mask is obtained by interpolation in dB on a logarithmic frequency scale as follows:

$$\text{MIB PSD mask}(f) = \begin{cases} PSD_1 + (PSD_2 - PSD_1) \times \frac{\log((f/\Delta f)/t_1)}{\log(t_2/t_1)} & f_1 < f \leq f_2 \end{cases}$$

4) *MIB PSD inband shaping*

if $t_1 = \text{roundup}(f_{pb_start}/\Delta f)$ then for $n = 1$ to $N - 1$:

if ($75 \leq t_1 \leq 273$) then for $n = 2$ to $N - 1$:

- The inband slope shall comply to:

$$\left| \frac{PSD_{n+1} - PSD_n}{t_{n+1} - t_n} \right| \leq 0.75 \text{ dB/tone}$$

- $\text{MAX}(PSD_n) - \text{MIN}(PSD_n) \leq 20 \text{ dB}$
- $\text{MAX PSD of the Limit mask} - 20 \text{ dB} \leq \text{MAX}(PSD_n) \leq \text{MAX PSD of the Limit mask}$
- The MIB PSD mask is obtained by interpolation in dB on a linear frequency scale as follows:

$$\text{MIB PSD mask}(f) = \begin{cases} PSD_n + (PSD_{n+1} - PSD_n) \times \frac{(f/\Delta f) - t_n}{t_{n+1} - t_n} & f_n < f \leq f_{n+1} \end{cases}$$

NOTE – If the first breakpoint has subcarrier index $75 \leq t_1 \leq 273$, then a stopband is created in the lower frequency part of the passband, with spectrum shaping applied to the remainder of the passband. If $t_1 = \text{roundup}(f_{pb_start}/\Delta f)$, then only spectrum shaping is applied over the whole passband.

5) *RFI band specification*

- A RFI band is specified in the CO-MIB PSD mask through a set of 4 breakpoints ($t(i + 1)$, $PSD(i + 1)$) to ($t(i + 4)$, $PSD(i + 4)$), as shown in Figure 8-1. In addition, the CO-MIB also contains an explicit indication that the pair ($t(i + 2)$, $t(i + 3)$) represents an RFI band (see ITU-T Rec. G.997.1).

- The restrictions on the breakpoints specifying an RFI band are:

$$\frac{PSD_{i+1} - PSD_{i+2}}{t_{i+1} - t_{i+2}} \leq 1.5 \text{ dB/tone}$$

$$PSD_{i+2} \geq \text{PSD}_{\text{Limitmask}}(f_{i+2}) - 33.5 \text{ dB}$$

$$PSD_{i+2} = PSD_{i+3}$$

$$PSD_{i+3} \geq \text{PSD}_{\text{Limitmask}}(f_{i+3}) - 33.5 \text{ dB}$$

$$\frac{PSD_{i+4} - PSD_{i+3}}{t_{i+4} - t_{i+3}} \leq 1.5 \text{ dB/tone}$$

– In the RFI band, the MIB PSD mask is given by following equations:

$$MIB\ PSD\ mask(f) = \begin{cases} PSD_{i+1} & f_{i+1} \leq f \leq f_{i+2} \\ PSD_{i+2} = PSD_{i+3} & f_{i+2} \leq f \leq f_{i+3} \\ PSD_{i+4} & f_{i+3} \leq f \leq f_{i+4} \end{cases}$$

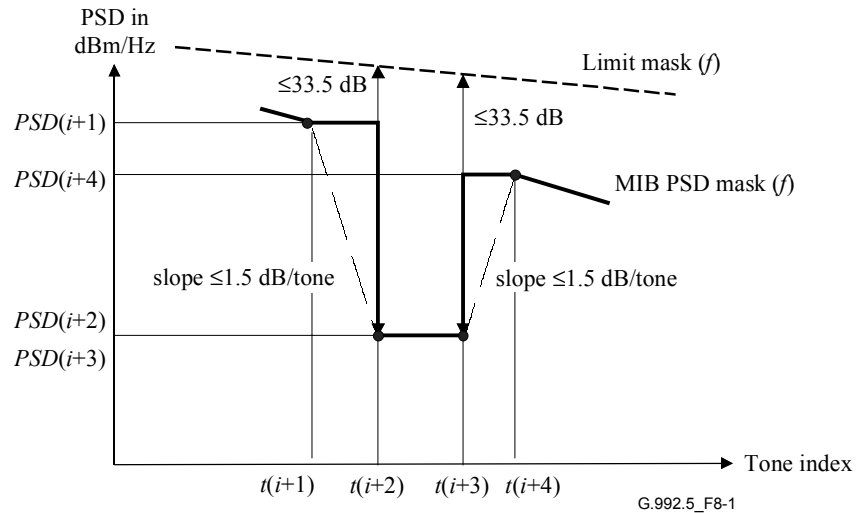

Figure 8-1/G.992.5 – Restrictions on breakpoints and MIB PSD mask (f)

The (informative) MIB PSD Template is defined as the CO-MIB PSD mask -3.5 dB, for $f_{lm_start} \leq f \leq f_{lm_stop}$, except for the MIB PSD stopband in the lower frequency part, which remains at -95 dBm/Hz, and the stopband of the RFI bands which remains at $PSD(i + 2)$.

The PSD mask to which the ATU-C transmitter shall comply at the U-C2 reference point shall be the minimum (at each frequency) of the Limit PSD mask (specified in Annexes A, B, or I) and the CO-MIB PSD mask specified through the CO-MIB.

The following figures give a number of examples of MIB PSD masks which can be constructed within the above restrictions. Figure 8-2 illustrates a number of PSD masks which introduce a stopband in the first part of the frequency band. Figure 8-3 illustrates the restrictions on the MIB PSD in-band shaping. The PSD toolbox techniques shown in these figures may be combined in practice.

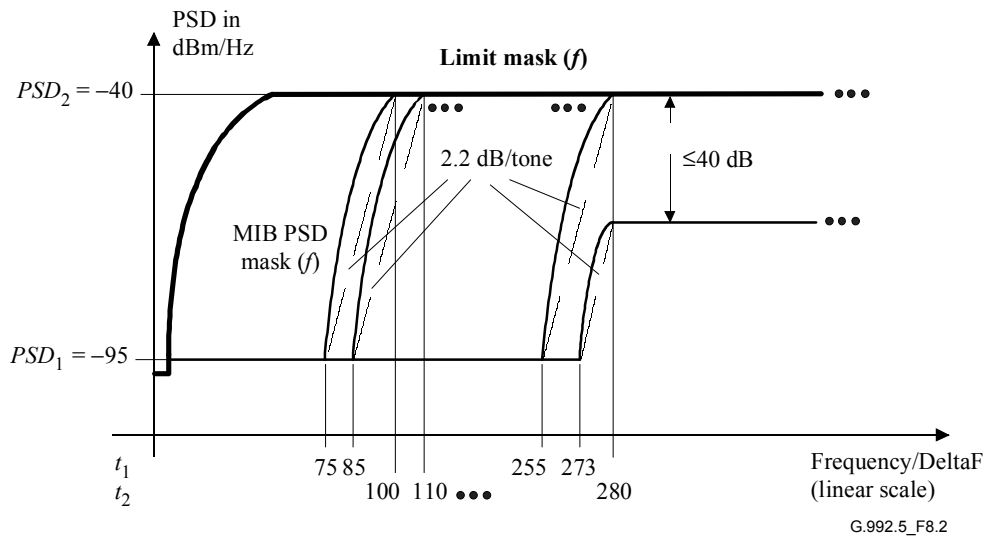

Figure 8-2/G.992.5 – Illustration of a stopband in the first part of the frequency band

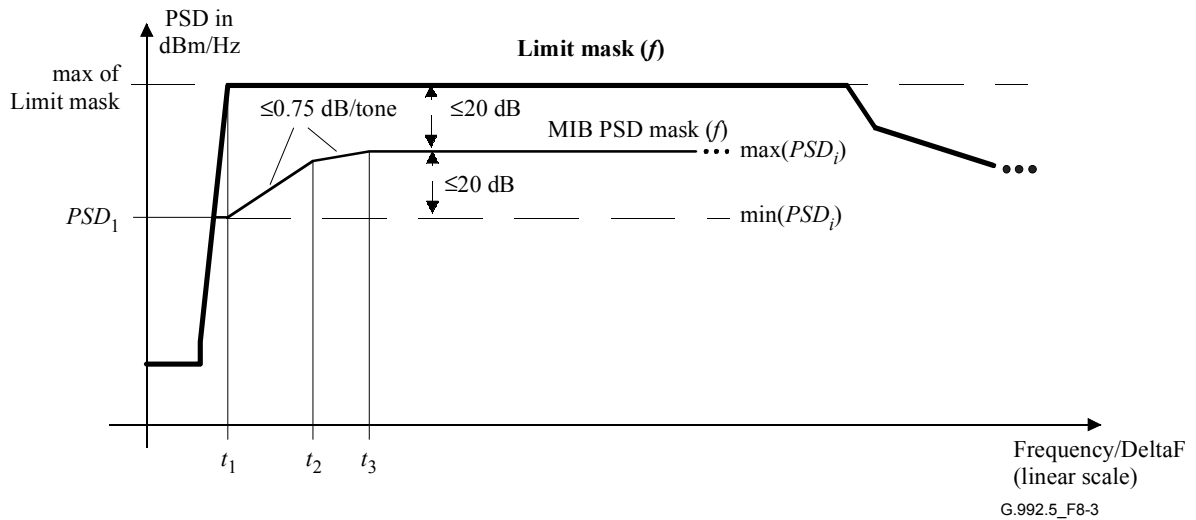

Figure 8-3/G.992.5 – Illustration of the restrictions on the MIB PSD in-band shaping

8.5.2 Mandatory and optional settings of control parameters

See 8.5.2/G.992.3.

8.5.3 Setting control parameters during initialization

See 8.5.3/G.992.3.

8.5.3.1 During the G.994.1 Phase

See 8.5.3.1/G.992.3.

8.5.3.2 During the channel analysis phase

The format of the PMD function control parameters involved in the MSG1 messages shall be as shown in Table 8-1.

Table 8-1/G.992.5 – Format of PMD function control parameters included in MSG1

Parameter	Format
<i>TARSNRM</i>	Unsigned 9-bit integer, 0 to 310 (0 to 31 dB in 0.1-dB steps).
<i>MINSNRM</i>	Unsigned 9-bit integer, 0 to 310 (0 to 31 dB in 0.1-dB steps).
<i>MAXSNRM</i>	Unsigned 9-bit integer, 0 to 310 (0 to 31 dB in 0.1-dB steps). The value 511 is a special value, indicating that excess margin relative to <i>MAXSNRM</i> need not be minimized (see 8.6.4/G.992.3), i.e., that the <i>MAXSNRM</i> value is effectively infinite.
<i>RA-MODE</i>	Unsigned 2-bit integer, values 1 to 3.
<i>PM-MODE</i>	Binary 2-bit indication, each set to 0 or 1.
<i>RA-USNRM</i>	Unsigned 9-bit integer, 0 to 310 (0 to 31 dB in 0.1-dB steps).
<i>RA-UTIME</i>	Unsigned 14-bit integer, 0 to 16383 (in seconds).
<i>RA-DSNRM</i>	Unsigned 9-bit integer, 0 to 310 (0 to 31 dB in 0.1-dB steps).
<i>RA-DTIME</i>	Unsigned 14-bit integer, 0 to 16383 (in seconds).
<i>BIMAX</i>	Unsigned 4 bit integer, 8 to 15.
<i>EXTGI</i>	Unsigned 8-bit integer, 0 to 255 (0 to 25.5 dB in 0.1-dB steps).
<i>CA-MEDLEY</i>	Unsigned 6-bit integer, 0 to 63 (times 512 symbols).
<i>WINDOW SAMPLES</i>	Window samples are represented by <i>NSCds</i> /64 entries. Each entry is 16-bit unsigned integer, in multiple of 2^{-16} (see 8.8.4).

The value *CA-MEDLEY* represents the minimum duration (in multiples of 512 symbols) of the MEDLEY state during the Initialization Channel Analysis Phase. It can be different for the ATU-C (*CA-MEDLEY_{us}* indicates the minimum length of the R-MEDLEY state) and the ATU-R (*CA-MEDLEY_{ds}* indicates the minimum length of the C-MEDLEY state). See 8.13.5.1.4 and 8.13.5.2.4/G.992.3.

The PMD function control parameters exchanged in the C-MSG1 message are listed in Table 8-2. Window samples shall be included only if windowing is applied (which is indicated in C-MSG-FMT, see 8.13.3.1.10).

Table 8-2/G.992.5 – PMD function control parameters included in C-MSG1

Octet Nr [i]	Parameter	Format PMD bits [8 × i + 7 to 8 × i + 0]
0	<i>TARSNRMds</i> (LSB)	[xxxx xxxx], bits 7 to 0
1	<i>TARSNRMds</i> (MSB)	[0000 00xx], bit 8
2	<i>MINSNRMds</i> (LSB)	[xxxx xxxx], bits 7 to 0
3	<i>MINSNRMds</i> (MSB)	[0000 000x], bit 8
4	<i>MAXSNRMds</i> (LSB)	[xxxx xxxx], bits 7 to 0
5	<i>MAXSNRMds</i> (MSB)	[0000 000x], bit 8
6	<i>RA-MODEds</i>	[0000 00xx], bits 1 to 0
7	<i>PM-MODE</i>	[0000 00xx], bits 1 to 0
8	<i>RA-USNRMds</i> (LSB)	[xxxx xxxx], bits 7 to 0
9	<i>RA-USNRMds</i> (MSB)	[0000 000x], bit 8
10	<i>RA-UTIMEds</i> (LSB)	[xxxx xxxx], bits 7 to 0
11	<i>RA-UTIMEds</i> (MSB)	[00xx xxxx], bits 13 to 8
12	<i>RA-DSNRMds</i> (LSB)	[xxxx xxxx], bits 7 to 0
13	<i>RA-DSNRMds</i> (MSB)	[0000 000x], bit 8

Table 8-2/G.992.5 – PMD function control parameters included in C-MSG1

Octet Nr [i]	Parameter	Format PMD bits [8 × i + 7 to 8 × i + 0]
14	<i>RA-DTIME</i> ds (LSB)	[xxxx xxxx], bits 7 to 0
15	<i>RA-DTIME</i> ds (MSB)	[00xx xxxx], bits 13 to 8
16	<i>BIMAX</i> ds	[0000 xxxx], bits 3 to 0
17	<i>EXTGI</i> ds	[xxxx xxxx], bits 7 to 0
18	<i>CA-MEDLEY</i> us	[00xx xxxx], bits 5 to 0
19	Reserved	[0000 0000]
20	<i>w</i> (0) (LSB)	[xxxx xxxx], bits 7 to 0
21	<i>w</i> (0) (MSB)	[xxxx xxxx], bits 15 to 8
...
18 + <i>NSC</i> ds/32	<i>w</i> (<i>NSC</i> ds/64 – 1) (LSB)	[xxxx xxxx], bits 7 to 0
19 + <i>NSC</i> ds/32	<i>w</i> (<i>NSC</i> ds/64 – 1) (MSB)	[xxxx xxxx], bits 15 to 8

The PMD function control parameters exchanged in the R-MSG1 message are listed in Table 8-3.

Table 8-3/G.992.5 – PMD function control parameters included in R-MSG1

Octet Nr [i]	Parameter	Format PMD bits [8 × i + 7 to 8 × i + 0]
0	<i>BIMAX</i> us	[0000 xxxx], bits 3 to 0
1	<i>EXTGI</i> us	[xxxx xxxx], bits 7 to 0
2	<i>CA-MEDLEY</i> ds	[00xx xxxx], bits 5 to 0
3		[0000 0000]

The value *EXTGI* shall be in the [0..*MAXNOMPSD* – *NOMPSD*] range. The value may or may not depend on the transmit PMD function's capabilities and the line characteristics identified during Channel Discovery Phase. The receive PMD function shall use *g_i* values in the [–14.5 .. + 2.5 + *EXTGI*] range. Depending on its capabilities and the line characteristics identified during Channel Discovery Phase, the receive PMD function may or may not use *g_i* values up to the allowed maximum value.

The ATU-C shall set the *REFPSD*ds, the downstream *tss_i* and the *EXTGI*ds values such that the downstream transmit *PSD* mask is not violated at any of the subcarriers in the downstream MEDLEYset, even if the *g_i* value requested by the ATU-R is as high as (2.5 + *EXTGI*) dB for one or more of those subcarriers.

NOTE – An extended range for *g_i* values can only be used if the transmit PSD function chooses to use a nominal transmit PSD level that is below the maximum transmit PSD level allowed by the CO-MIB (see 8.5.1) and can only be used within the transmit PSD mask limitations set by the CO-MIB.

8.5.3.3 During the Exchange Phase

The format of the PMD function control and test parameters involved in the PARAMS messages shall be as shown in Table 8-4.

Table 8-4/G.992.5 – Format of PMD function control parameters included in PARAMS

Parameter	Format
<i>LATN</i>	Test parameter (see 8.12.3/G.992.3)
<i>SATN</i>	Test parameter (see 8.12.3/G.992.3)
<i>SNRM</i>	Test parameter (see 8.12.3/G.992.3)
<i>ATTNDR</i>	Test parameter (see 8.12.3/G.992.3)
<i>ACTATP</i>	Test parameter (see 8.12.3/G.992.3)
<i>TRELLIS</i>	Binary indication, set to 0 or 1.
Bits and Gains table	Bits and gains table is represented by $NSC - 1$ entries or $2 \times (NSC - 1)$ octets. Each entry is a 16-bit unsigned integer. Bits in 4 LSB, Gain in 12 MSB, linear scale. The gain value shall be represented with 3 bits before and 9 bits after the decimal point, i.e., a granularity of 1/512 in linear scale.
Tone ordering table	Tone ordering is represented by $NSC - 1$ entries. Each entry is an 11-bit unsigned integer, representing a subcarrier index in the 1 to $NSC - 1$ range.

The test parameters are mapped into messages using an integer number of octets per parameter value. In case the parameter value as defined in 8.12.3/G.992.3 is represented with a number of bits that is not an integer number of octets, the parameter value shall be mapped into the least significant bits of the message octets. Unused more significant bits shall be set to 0 for unsigned parameter values and shall be set to the sign bit for signed parameter values.

The PMD function control parameters and test parameters exchanged in the C-PARAMS message are listed in Table 8-5.

Table 8-5/G.992.5 – PMD function control parameters included in C-PARAMS

Octet Nr [i]	Parameter	Format PMD bits [$8 \times i + 7$ to $8 \times i + 0$]
0	<i>LATNus</i> (LSB)	[xxxx xxxx], bits 7 to 0
1	<i>LATNus</i> (MSB)	[0000 00xx], bits 9 and 8
2	<i>SATNus</i> (LSB)	[xxxx xxxx], bits 7 to 0
3	<i>SATNus</i> (MSB)	[0000 00xx], bits 9 and 8
4	<i>SNRMus</i> (LSB)	[xxxx xxxx], bits 7 to 0
5	<i>SNRMus</i> (MSB)	[ssss sxxx], bits 10 to 8
6	<i>ATTNDRus</i> (LSB)	[xxxx xxxx], bits 7 to 0
7	<i>ATTNDRus</i>	[xxxx xxxx], bits 15 to 8
8	<i>ATTNDRus</i>	[xxxx xxxx], bits 23 to 16
9	<i>ATTNDRus</i> (MSB)	[xxxx xxxx], bits 31 to 24
10	<i>ACTATPus</i> (LSB)	[xxxx xxxx], bits 7 to 0
11	<i>ACTATPus</i> (MSB)	[ssss sxxx], bits 9 and 8
12	<i>TRELLISus</i>	[0000 000x], bit 0
13	Reserved	[0000 0000]
14	Upstream Bits and Gains For subcarrier 1 (LSB)	[gggg bbbb], bits 7 to 0

Table 8-5/G.992.5 – PMD function control parameters included in C-PARAMS

Octet Nr [i]	Parameter	Format PMD bits [$8 \times i + 7$ to $8 \times i + 0$]
15	Upstream Bits and Gains For subcarrier 1 (MSB)	[gggg gggg], bits 15 to 8
..
$10 + 2 \times NSCus$	Upstream Bits and Gains Subcarrier $NSCus - 1$ (LSB)	[gggg bbbb], bits 7 to 0
$11 + 2 \times NSCus$	Upstream Bits and Gains Subcarrier $NSCus - 1$ (MSB)	[gggg gggg], bits 15 to 8
$12 + 2 \times NSCus$	Reserved	[0000 0000]
$13 + 2 \times NSCus$	Reserved	[0000 0000]
$14 + 2 \times NSCus$	Upstream Tone ordering First subcarrier to map (LSB)	[xxxx xxxx], bits 7 to 0
$15 + 2 \times NSCus$	Upstream Tone ordering First subcarrier to map (MSB)	[0000 0xxx], bits 10 to 8
...
$10 + 4 \times NSCus$	Upstream Tone ordering Last subcarrier to map (LSB)	[xxxx xxxx], bits 7 to 0
$11 + 4 \times NSCus$	Upstream Tone ordering Last subcarrier to map (MSB)	[0000 0xxx], bits 10 to 8

The PMD function control parameters exchanged in the R-PARAMS message are listed in Table 8-6.

Table 8-6/G.992.5 – PMD function control parameters included in R-PARAMS

Octet Nr [i]	Parameter	Format PMD bits [$8 \times i + 7$ to $8 \times i + 0$]
0	<i>LATNds</i> (LSB)	[xxxx xxxx], bits 7 to 0
1	<i>LATNds</i> (MSB)	[0000 00xx], bits 9 and 8
2	<i>SATNds</i> (LSB)	[xxxx xxxx], bits 7 to 0
3	<i>SATNds</i> (MSB)	[0000 00xx], bits 9 and 8
4	<i>SNRMds</i> (LSB)	[xxxx xxxx], bits 7 to 0
5	<i>SNRMds</i> (MSB)	[ssss sxxx], bits 10 to 8
6	<i>ATTNDRds</i> (LSB)	[xxxx xxxx], bits 7 to 0
7	<i>ATTNDRds</i>	[xxxx xxxx], bits 15 to 8
8	<i>ATTNDRds</i>	[xxxx xxxx], bits 23 to 16
9	<i>ATTNDRds</i> (MSB)	[xxxx xxxx], bits 31 to 24
10	<i>ACTATPds</i> (LSB)	[xxxx xxxx], bits 7 to 0
11	<i>ACTATPds</i> (MSB)	[ssss sxxx], bits 9 and 8
12	<i>TRELLISds</i>	[0000 000x], bit 0
13	Reserved	[0000 0000]
14	Downstream Bits and Gains For subcarrier 1 (LSB)	[gggg bbbb], bits 7 to 0

Table 8-6/G.992.5 – PMD function control parameters included in R-PARAMS

Octet Nr [i]	Parameter	Format PMD bits [8 × i + 7 to 8 × i + 0]
15	Downstream Bits and Gains For subcarrier 1 (MSB)	[gggg gggg], bits 15 to 8
...
10 + 2 × NSCds	Downstream Bits and Gains Subcarrier NSCds – 1 (LSB)	[gggg bbbb], bits 7 to 0
11 + 2 × NSCds	Downstream Bits and Gains Subcarrier NSCds – 1 (MSB)	[gggg gggg], bits 15 to 8
12 + 2 × NSCds	Reserved	[0000 0000]
13 + 2 × NSCds	Reserved	[0000 0000]
14 + 2 × NSCds	Downstream Tone ordering First subcarrier to map (LSB)	[xxxx xxxx], bits 7 to 0
15 + 2 × NSCds	Downstream Tone ordering First subcarrier to map	[0000 0xxx], bits 10 to 8
...
10 + 4 × NSCds	Downstream Tone ordering Last subcarrier to map	[xxxx xxxx], bits 7 to 0
11 + 4 × NSCds	Downstream Tone ordering Last subcarrier to map	[0000 0xxx], bits 10 to 8

8.6 Constellation encoder for data symbols

See 8.6/G.992.3.

8.7 Constellation encoder for synchronization and L2 exit symbols

See 8.7/G.992.3.

8.8 Modulation

See 8.8/G.992.3.

8.8.1 Subcarriers

See 8.8.1/G.992.3.

8.8.2 Inverse Discrete Fourier Transform

See 8.8.2/G.992.3.

8.8.3 Cyclic prefix and cyclic suffix

With a data symbol rate of 4 kHz, a DMT subcarriers spacing of $\Delta f = 4.3125$ kHz and an IDFT size of $2 \times NSC$, a cyclic prefix of $(2 \times NSC \times 5/64)$ samples could be used. That is:

$$\left(2 \times NSC + 2 \times NSC \times \frac{5}{64} \right) \times 4.0 \text{ kHz} = (2 \times NSC) \times 4.3125 \text{ kHz} = f_s \text{ (the sample frequency)}$$

The cyclic prefix shall, however, be shortened to $(2 \times NSC \times 4/64 = NSC/8)$ samples, and a synchronization symbol (with a length of $2 \times NSC \times 68/64$ samples) is inserted after every 68 data symbols. That is:

$$\left(2 \times NSC \times \frac{4}{64} + 2 \times NSC\right) \times 69 = \left(2 \times NSC \times \frac{5}{64} + 2 \times NSC\right) \times 68$$

For symbols with cyclic prefix, the last $NSC/8$ samples of output of the IDFT (x_n for $n = 2 \times NSC - NSC/8$ to $2 \times NSC - 1$) shall be prepended to the block of $2 \times NSC$ samples, to form a block of $(2 \times NSC \times 17/16)$ samples. Symbols with cyclic prefix are transmitted at a symbol rate of $4.3125 \times 16/17 \approx 4.059$ kHz.

In the downstream direction, the ATU-C transmitter may apply windowing. If windowing is applied, symbols with cyclic prefix shall also have a cyclic suffix. If windowing is not applied, symbols with cyclic prefix shall not have a cyclic suffix. For symbols with a cyclic suffix, the first $NSCds/32$ samples of output of the IDFT (x_n for $n = 0$ to $NSCds/32 - 1$) shall be appended to the block of $(2 \times NSC \times 17/16)$ samples, to form a block of $(2 \times NSC \times 69/64)$ samples. Symbols with cyclic suffix are transmitted at a symbol rate of $4.3125 \times 16/17 \approx 4.059$ kHz.

The cyclic prefix (and suffix if windowing is applied) shall be used for all symbols transmitted starting from the Channel Analysis Phase of the initialization sequence (see 8.13.5). Before the Channel Analysis Phase, all symbols shall be transmitted without cyclic prefix and without cyclic suffix. Symbols transmitted without cyclic prefix and without cyclic suffix are transmitted at a symbol rate of 4.3125 kHz.

If an oversampled IDFT is used (i.e., $N > NSC$, see 8.8.2), the number of cyclic prefix and cyclic suffix samples shall be adapted accordingly. For symbols with cyclic prefix, the last $N/8$ samples of output of the IDFT (x_n for $n = 2 \times N - N/8$ to $2 \times N - 1$) shall be prepended to the block of $2 \times N$ samples, to form a block of $(2 \times N \times 17/16)$ samples. For symbols with cyclic suffix, the first $N/32$ samples of output of the IDFT (x_n for $n = 0$ to $N/32 - 1$) shall be appended to the block of $(2 \times N \times 17/16)$ samples, to form a block of $(2 \times N \times 69/64)$ samples.

8.8.4 Parallel/Serial convertor

The block of x_n samples ($n = 0$ to $2 \times NSC - 1$) shall be read out to the digital-to-analog converter (DAC) in sequence.

If no cyclic prefix is used, the DAC samples y_n in sequence are:

$$y_n = x_n \quad \text{for } n = 0 \text{ to } 2 \times NSC - 1$$

If a cyclic prefix is used, the DAC samples y_n in sequence are (see Figure 8-5):

$$y_n = x_n - \left(2 \times NSC - \frac{NSC}{8}\right) \quad \text{for } n = 0 \text{ to } \frac{NSC}{8} - 1$$

$$y_n = x_n - \left(\frac{NSC}{8}\right) \quad \text{for } n = \frac{NSC}{8} \text{ to } \left(\frac{17}{16}\right) \times 2 \times NSC - 1$$

If for the downstream direction, a cyclic prefix is used and a cyclic suffix is used (windowing), then the DAC samples in sequence shall be:

$$[1 - w(i)] \times prev_x(i) + w(i) \times x\left(2 \times NSC - \frac{NSC}{8} + i\right) \quad \text{for } i = 0 \text{ to } \frac{NSC}{32} - 1$$

$$x\left(2 \times NSC - \frac{NSC}{8} + i\right) \quad \text{for } i = \frac{NSC}{32} \text{ to } \frac{NSC}{8} - 1$$

$$x(i) \quad \text{for } i = 0 \text{ to } 2 \times NSC - 1$$

where the $prev_x(i)$ corresponds to the cyclic suffix of the previous symbol (see 8.3.3). The $NSC/32$ samples in the cyclic suffix of the previous symbol and the first $NSC/32$ samples of the cyclic prefix of the current symbol are transmitted as overlapping in time, i.e., a weighted sum is transmitted. The above defined DAC sample sequence corresponds to applying a $(2 \times NSC \times 69/64)$ samples window. The window in discrete time representation (set of w_i) shall be defined as follows:

$$\begin{aligned}
 w_i & \text{ is vendor discretionary} & \text{for } i = 0 \text{ to } \frac{NSC}{64} - 1 \\
 w_i & = 1 - w\left(\frac{NSC}{32} - 1 - i\right) & \text{for } i = \frac{NSC}{64} \text{ to } \frac{NSC}{32} - 1 \\
 w_i & = 1 & \text{for } i = \frac{NSC}{32} \text{ to } 2 \times NSC \times \frac{17}{16} - 1 \\
 w_i & = w\left(2 \times NSC \times \frac{69}{64} - 1 - i\right) & \text{for } i = 2 \times NSC \times \frac{17}{16} \text{ to } 2 \times NSC \times \frac{69}{64} - 1
 \end{aligned}$$

Each of the time discrete window samples shall be represented in a 16-bit unsigned integer as a multiple of 65536, in the 0 to $1 - 2^{-16}$ range.

The window in continuous time representation ($w(t)$) shall be defined as follows:

$$w(t) = \sum_{i=0}^{2 \times NSC \times \frac{69}{64} - 1} \sin c(t \times f_s - i) \cdot w_i$$

The ATU-C shall indicate in the C-MSG-FMT message whether windowing is applied or not. In case windowing is applied, the C-MSG1 shall contain the window samples $w(i)$ for $i=0$ to $NSC/64 - 1$ (see 8.5.3.2). These $NSC/64$ samples define the complete window of $2 \times NSC \times 69/64$ samples as defined above.

NOTE – The C-MSG1 message is transmitted in the Initialization procedures (see 8.13) and Short initialization procedures (see 8.14). It is not transmitted in the Loop diagnostics mode procedures (see 8.15).

If an oversampled IDFT is used (i.e., $N > NSC$, see 8.8.2), the number of window samples shall be adapted accordingly from the window in continuous time representation $w(t)$ to a window of $2 \times N \times 69/64$ samples. The ATU-C shall truncate in time and round samples to the same precision as the (non-oversampled) window samples communicated to the ATU-R in the C-MSG1 message. The ATU-R receiver shall take into account the error that the ATU-C transmitter may introduce through this time truncation and value rounding process.

Filtering may be applied to the sample sequence going into the DAC.

8.8.5 DAC and AFE

The DAC produces an analog signal that is passed through the analog front-end (AFE) and transmitted across the digital subscriber line (DSL). The analog front end may include filtering.

If the transmit PMD function is configured in the L3 idle state, then a zero output voltage shall be transmitted at the U-C2 (for ATU-C) and the U-R2 (for ATU-R) reference point (see reference model in 5.4). The analog front end may include filtering.

8.9 Transmitter dynamic range

See 8.9/G.992.3.

8.10 Transmitter spectral masks

See 8.10/G.992.3.

In this Recommendation, Annex J is for further study.

8.11 Control plane procedures

See 8.11/G.992.3.

8.12 Management plane procedures

See 8.12/G.992.3.

8.13 Initialization procedures

See 8.13/G.992.3.

8.13.1 Overview

See 8.13.1/G.992.3.

8.13.2 G.994.1 phase

See 8.13.2/G.992.3.

8.13.2.1 Handshake – ATU-C

See 8.13.2.1/G.992.3.

The G.992.5 handshake codepoints are defined in ITU-T Rec. G.994.1 [2].

8.13.2.2 Handshake – ATU-R

See 8.13.2.2/G.992.3.

8.13.2.3 G.994.1 transmit PSD levels

See 8.13.2.3/G.992.3.

8.13.2.4 Spectral bounds and shaping parameters

The spectrum bounds and shaping parameters shall be applied as described in 8.13.2.4/G.992.3, with the following differences:

- If windowing is applied in the downstream direction, the $w^2(f)$ used in Equation 8-1/G.992.3 is the Fourier transform of the autocorrelation function of the window $w(t)$ (see 8.8.4), normalized such that the integral of $W^2(f)$ is equal to unity.
- The downstream tss_i values as indicated in the G.994.1 CL message shall be used in the Channel Discovery Phase.
- Starting from the transceiver training phase, tss_i values for subcarriers included the downstream SUPPORTEDset shall be ceiled according to the following relationship, before being applied relative to the *REFPSDds* level:

$$ceiled_log_tss_i = MIN(\log_tss_i + PCBds, 0 \text{ dB})$$

The *ceiled_log_tss_i* shall only be computed at beginning of transceiver training phase and shall not be adapted when *PCBds* changes during showtime (e.g., with entry into the L2 power management state or with L2 trim, see 9.4.1.7).

- Starting from the transceiver training phase, tss_i values for subcarriers not included in the downstream SUPPORTEDset shall be applied as indicated in the G.994.1 CL message, relative to the *REFPSDds* level.

NOTE 1 – This corresponds to a ceiling of the transmit PSD to the *REFPSDds* level over the subcarriers included in the SUPPORTEDset, and a lowering of the transmit PSD by *PCBds* dB over the subcarriers not included in the SUPPORTEDset. Depending on the spectrum shaping applied through the tss_i values as indicated in the G.994.1 CL message, this may reduce the transmit PSD level only in a part or in the whole passband.

NOTE 2 – Because the ATU-C applies the downstream powercutback through a ceiling of the downstream tss_i values before being applied relative to the $REFPSDds$ level. This implies that the ATU-R receiver will have to take into account the downstream tss_i values indicated in the G.994.1 CL message, when determining the downstream powercutback to be requested through the R-MSG-PCB message.

Figure 8-4 shows an example of the downstream tss_i values as a function of the subcarrier index i , for the case that the SUPPORTEDset contains the subcarriers with index $i = 100$ to 399 and $i = 484$ to 500 and for $N = 2 \times NSC = 1024$ (oversampled IDFT). At frequencies $i \times \Delta f$, with $100 \leq i \leq 399$ and $484 \leq i \leq 500$ and $\Delta f = 4.3125$ kHz, the tss_i value is chosen such that for ideal filters, ideal DAC and ideal AFE, the spectrum on the U-interface corresponds with the transmit spectrum given in Annex A. At frequencies $i \times \Delta f$, with $400 \leq i \leq 483$ the carriers are not in the SUPPORTEDset to avoid the HAM-band [1.81, 2.0] MHz, taking into account a 20-tone transition band. In this case no windowing is assumed, and therefore some extra notch-filter need to be applied to reach a stopband of -80 dBm/Hz.

Transmit spectrum shaping values and spectrum $S(f)$ [100, 500] with HAM-band 1.8-2 MHz (no windowing)

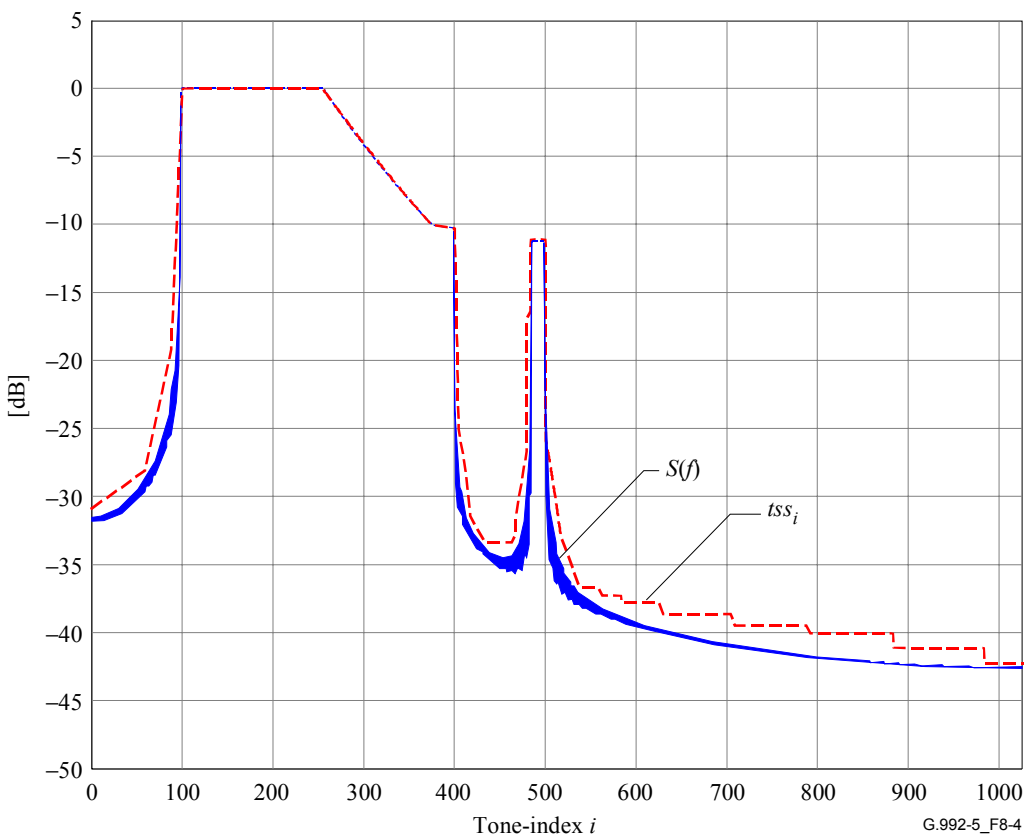

Figure 8-4/G.992.5 – Example of the downstream \log_{tss_i} values (in dB) as function of the subcarrier index

NOTE 3 – For the downstream direction, the CO-MIB contains a per subcarrier indication of the maximum transmit PSD level at the U-C reference point, to apply at all times, except during the G.994.1 Phase. The CO-MIB also contains a per subcarrier indication whether the subcarrier is or is not allowed to be sent starting from the initialization Channel Analysis phase. From this information and taking into account its own capabilities, the ATU-C selects the downstream SUPPORTEDset of subcarriers and computes the CL downstream spectrum shaping parameter block information.

NOTE 4 – For the upstream direction, the CO-MIB contains a per subcarrier indication whether the subcarrier is or is not allowed to be sent starting from the initialization Channel Analysis phase. This information is conveyed to the ATU-R in the CL upstream spectrum shaping parameter block (through SUPPORTEDset indication and only using tss_i values 0 and 1 in linear scale). From this information and

taking into account its own capabilities, the ATU-R selects the upstream SUPPORTEDset of subcarriers and computes the CLR upstream spectrum shaping parameter block information.

8.13.3 Channel Discovery Phase

See 8.13.3/G.992.3.

8.13.3.1 ATU-C channel discovery

See 8.13.3.1/G.992.3.

8.13.3.1.1 C-QUIET1

See 8.13.3.1.1/G.992.3.

8.13.3.1.2 C-COMB1

The duration of the C-COMB1 state is of fixed length. In the C-COMB1 state, the ATU-C shall transmit 128 C-COMB symbols.

During this state, the ATU-R performs timing recovery and measures some characteristics of the downstream channel for C-TREF pilot tone selection and for the estimation of the required ATU-R minimum Upstream Power Cutback and ATU-R minimum Downstream Power Cutback. These functions can be continued during C-COMB2.

The C-COMB symbol shall be defined as a wideband multi-tone symbol containing the 16 subcarriers with index 11, 23, 35, 47, 59, 64, 71, 83, 95, 107, 119, 143, 179, 203, 227 and 251 and all subsequent subcarriers with index $251 + k \times 24$ (with k integer such that the subcarrier index is in the 256 to $NSCds - 1$ range). The subcarrier spacing has been selected to minimize audible interference into the POTS band prior to applying cutbacks that may be required in the presence of an off-Hook POTS terminal and to limit aggregate transmit power to 8.9 dBm (i.e., the 12 dB power cutback level).

The subcarriers contained in the C-COMB symbol shall modulate the same data bits that are used for the C-REVERB symbols, in such a way that same subcarrier indexes modulate the same data bits with the same 4-QAM constellation, as defined in 8.13.4.1.1. The subcarriers not contained in the C-COMB symbol shall be transmitted at no power (i.e., $X_i = Y_i = 0$).

The C-COMB1 state shall be followed by the C-QUIET2 state.

8.13.3.1.3 C-QUIET2

See 8.13.3.1.3/G.992.3.

8.13.3.1.4 C-COMB2

See 8.13.3.1.4/G.992.3.

8.13.3.1.5 C-ICOMB1

See 8.13.3.1.5/G.992.3.

8.13.3.1.6 C-LINEPROBE

See 8.13.3.1.6/G.992.3.

8.13.3.1.7 C-QUIET3

See 8.13.3.1.7/G.992.3.

8.13.3.1.8 C-COMB3

See 8.13.3.1.8/G.992.3.

8.13.3.1.9 C-ICOMB2

See 8.13.3.1.9/G.992.3.

8.13.3.1.10 C-MSG-FMT

The C-MSG-FMT state is of fixed length. In the C-MSG-FMT state, the ATU-C shall transmit 96 symbols of C-COMB or C-ICOMB to modulate the C-MSG-FMT message and CRC. The C-MSG-FMT message conveys information about the presence, format and length of subsequent ATU-C and ATU-R messages.

The C-MSG-FMT message, m , is defined by:

$$m = \{m_{15}, \dots, m_0\}$$

Bits shall be defined as shown in Table 8-7.

Table 8-7/G.992.5 – Bit definition for the C-MSG-FMT message

Bit index	Parameter	Definition
0	<i>FMT_R-REVERB1</i> (value 0 or 1)	Set to 1 indicates that the ATU-C requests an extended duration of the R-REVERB1 state. Set to 0 indicates it does not.
1		Reserved, set to 0.
2	<i>FMT_C-REVERB4</i> (value 0 or 1)	Set to 1 indicates that the ATU-C requests an extended duration of the C-REVERB4 state. Set to 0 indicates it does not.
7..3	<i>FMT_R-QUIET4</i> (value 0 to 31)	The (0 to 31) value mapped in these bits indicates the duration of the R-QUIET4 state. The MSB shall be mapped on the higher message bit index.
8	<i>FMT_C-MSG-PCB</i>	Set to 1 indicates that the C-MSG-PCB message shall include the C-BLACKOUT bits. Set to 0 indicates it shall not.
9	<i>FMT_C-MSG1</i>	Set to 1 indicates that windowing is applied with window samples included in the C-MSG1 message. Set to 0 indicates no windowing is applied and no window samples are included in C-MSG1 message.
10	<i>FMT-C-MEDLEYPRBS</i>	Set to 1 indicates that the ATU-C requests to use the higher order PRBS for the C-MEDLEY data pattern (see 8.13.5.1.4).
15..11		Reserved, set to 0.

The 16 bits m_0 - m_{15} shall be transmitted in 48 symbol periods (m_0 first and m_{15} last). A zero bit shall be transmitted as three consecutive C-COMB symbols. A one bit shall be transmitted as three consecutive C-ICOMB symbols.

After the C-MSG-FMT message has been transmitted, a CRC shall be appended to the message. The 16 CRC bits shall be computed from the 16 message m bits using the equation:

$$c(D) = a(D)D^{16} \text{ modulo } g(D)$$

where:

$$a(D) = m_0D^{15} + m_1D^{14} \dots + m_{15}$$

is the message polynomial formed from the 16 bits of the C-MSG-FMT message, with m_0 the least significant bit of the first octet of the C-MSG-FMT message:

$$g(D) = D^{16} + D^{12} + D^5 + 1$$

is the CRC generator polynomial, and

$$c(D) = c_0D^{15} + c_1D^{14} \dots + c_{14}D + c_{15}$$

is the CRC check polynomial.

The 16 bits c_0 - c_{15} shall be transmitted in 48 symbol periods (c_0 first and c_{15} last) using the same modulation as used to transmit the message m .

The C-MSG-FMT state shall be followed by the C-MSG-PCB state.

8.13.3.1.11 C-MSG-PCB

See 8.13.3.1.11/G.992.3.

8.13.3.1.12 C-QUIET4

See 8.13.3.1.12/G.992.3.

8.13.3.2 ATU-R channel discovery

See 8.13.3.2/G.992.3.

8.13.3.2.1 R-QUIET1

See 8.13.3.2.1/G.992.3.

8.13.3.2.2 R-COMB1

See 8.13.3.2.2/G.992.3.

8.13.3.2.3 R-QUIET2

See 8.13.3.2.3/G.992.3.

8.13.3.2.4 R-COMB2

See 8.13.3.2.4/G.992.3.

8.13.3.2.5 R-ICOMB1

See 8.13.3.2.5/G.992.3.

8.13.3.2.6 R-LINEPROBE

See 8.13.3.2.6/G.992.3.

8.13.3.2.7 R-QUIET3

See 8.13.3.2.7/G.992.3.

8.13.3.2.8 R-COMB3

See 8.13.3.2.8/G.992.3.

8.13.3.2.9 R-ICOMB2

See 8.13.3.2.9/G.992.3.

8.13.3.2.10 R-MSG-FMT

The R-MSG-FMT state is of fixed length. In the R-MSG-FMT state, the ATU-R shall transmit 96 symbols of R-COMB or R-ICOMB to modulate the R-MSG-FMT message and CRC. The R-MSG-FMT message conveys information about the presence, format and length of subsequent ATU-C and ATU-R messages.

The R-MSG-FMT message, m , is defined by:

$$m = \{m_{15}, \dots, m_0\}$$

Bits shall be defined as shown in Table 8-8.

Table 8-8/G.992.5 – Bit definition for the R-MSG-FMT message

Bit index	Parameter	Definition
0	<i>FMT-R-REVERB1</i> (value 0 or 1)	Set to 1 indicates that the ATU-R requests an extended duration of the R-REVERB1 state. Set to 0 indicates it does not.
1		Reserved, set to 0.
2	<i>FMT-C-REVERB4</i> (value 0 or 1)	Set to 1 indicates that the ATU-R requests an extended duration of the C-REVERB4 state. Set to 0 indicates it does not.
6..3	<i>FMT-C-TREF1</i> (value 1 to 15)	The value mapped in these bits indicates the minimum duration of the C-TREF1 state. The MSB shall be mapped on the higher message bit index.
7	<i>FMT-R-MSG-PCB</i> (value 0 or 1)	Set to 1 indicates that the R-MSG-PCB message shall include the R-BLACKOUT bits. Set to 0 indicates it shall not.
8	<i>FMT-C-TREF2</i> (value 0 or 1)	Indicates that the ATU-R requests the ATU-C to transmit C-TREF symbols (if set to 1) or C-QUIET symbols (if set to 0) during R-ECT.
9	<i>FMT-C-PILOT</i> (value 0 or 1)	Set to 1 indicates that the ATU-R requests the ATU-C to transmit a fixed 4-QAM constellation point on the C-TREF pilot tone. Set to 0 indicates it does not.
10	<i>FMT-C-MEDLEYPRBS</i>	Set to 1 indicates that the ATU-R requests to use the higher order PRBS for the C-MEDLEY data pattern (see 8.13.5.1.4).
15..11		Reserved, set to 0.

The 16 bits m_0 - m_{15} shall be transmitted in 48 symbol periods (m_0 first and m_{15} last). A zero bit shall be transmitted as three consecutive R-COMB symbols. A one bit shall be transmitted as three consecutive R-ICOMB symbols.

After the R-MSG-FMT message has been transmitted, a CRC shall be appended to the message. The 16 CRC bits shall be computed in the same way as for the C-MSG-FMT message. The 16 bits c_0 - c_{15} shall be transmitted in 48 symbol periods (c_0 first and c_{15} last) using the same modulation as used to transmit the message m .

The R-MSG-FMT state shall be followed by the R-MSG-PCB state.

8.13.3.2.11 R-MSG-PCB

In each direction the transmit power will be reduced by a power cutback which is the highest of the power cutback values determined by the ATU-R and the ATU-C. The ATU-R can consider its receiver dynamic range as determined by observing C-COMB1, and the local line conditions determined by the optional R-LINEPROBE when determining its cutback levels.

The R-MSG-PCB state is of fixed length. In the R-MSG-PCB state, the ATU-R shall transmit 144 or $144 + 3 \times NSCds$ symbols of R-COMB or R-ICOMB to modulate the R-MSG-PCB message and CRC, depending on whether the R-BLACKOUT bits are included or not. The R-MSG-PCB message conveys the ATU-R determined power cutback levels for both the upstream and downstream directions, the hook status as known by the ATU-R, the signal used for timing recovery during different states and the downstream BLACKOUT bits.

The ATU-R shall indicate in the R-MSG-FMT message whether the R-MSG-PCB message includes the R-BLACKOUT bits or not. If the R-MSG-PCB does not include the R-BLACKOUT bits, the R-MSG-PCB message, m , is defined by:

$$m = \{m_{31}, \dots, m_0\}$$

If the R-MSG-PCB includes the R-BLACKOUT bits, the R-MSG-PCB message, m , is defined by:

$$m = \{m_{31 + NSCds}, \dots, m_0\}$$

Bits shall be defined as shown in Table 8-9.

Table 8-9/G.992.5 – Bit definition for the R-MSG-PCB message

Bit index	Parameter	Definition
5..0	<i>R-MIN_PCB_DS</i>	ATU-R Minimum Downstream Power Cutback (6-bit value with MSB in bit 5 and LSB in bit 0)
11..6	<i>R-MIN_PCB_US</i>	ATU-R Minimum Upstream Power Cutback (6-bit value with MSB in bit 11 and LSB in bit 6)
13..12	<i>HOOK_STATUS</i>	Hook Status (2-bit value with MSB in bit 13 and LSB in bit 12)
15..14		Reserved, set to 0.
26..16	<i>C-PILOT</i>	Subcarrier index of downstream pilot tone (11-bit value with MSB in bit 26 and LSB in bit 16)
31..27		Reserved, set to 0.
31 + <i>NSCds</i> ..32	<i>R-BLACKOUT</i>	Blackout indication per subcarrier (subcarrier $NSCds - 1$ in bit 31 + <i>NSCds</i> , subcarrier 0 in bit 32). Bit 32 shall be set to 0 (i.e., no blackout of DC subcarrier)

The ATU-R Minimum Downstream Power Cutback level shall be coded as defined in Table 8-10.

Table 8-10/G.992.5 – ATU-R minimum downstream power cutback

Value (6-bit)	ATU-R minimum downstream power cutback (dB)
0	0
1	1
...	...
40	40
41-63	Reserved

The ATU-R Minimum Upstream Power Cutback level shall be coded as defined in Table 8-11.

Table 8-11/G.992.5 – ATU-R minimum upstream power cutback

Value (6-bit)	ATU-R minimum upstream power cutback (dB)
0	0
1	1
...	...
40	40
41-63	Reserved

The hook status shall be coded as defined in Table 8-12. The hook state "Unknown" is intended to be indicated by a device that normally indicates the on- or off- hook state. The state "Not capable to detect" is intended to be indicated by a device that never sets the on or on hook state (e.g., is not capable or disabled to detect the hook state).

Table 8-12/G.992.5 – Hook status

Value (2-bit)	Hook status
0	Unknown
1	On-hook
2	Off-hook
3	Not capable to detect

The C-PILOT value shall indicate the index of the C-TREF pilot subcarrier to be used by the ATU-C for the C-TREF timing reference and to be used by the ATU-R during C-TREF1/C-TREF2 for timing recovery. The spectral shaping information exchanged during the G.994.1 phase and the BLACKOUT information exchanged in R-MSG-PCB allows the ATU-R to determine the set of subcarriers the ATU-C will transmit in and after the Channel Analysis Phase (i.e., to determine the MEDLEYset, see 8.13.2.4). The ATU-R shall select a C-TREF pilot subcarrier from the MEDLEYset.

The R-BLACKOUT bits shall contain the R-BLACKOUT bit settings for each of the subcarriers 1 to $NSCds - 1$. The R-BLACKOUT bit set to 0 for a particular subcarrier indicates that the ATU-C shall transmit that subcarrier at the ATU-C reference transmit PSD level ($REFPDSds$) level, and including spectral shaping, for the remainder of initialization, starting from the Transceiver Training Phase. The R-BLACKOUT bit be set to 1 indicates that the ATU-C shall transmit no power ("blackout") on that subcarrier, for the remainder of initialization, starting from the Transceiver Training Phase.

An R-MSG-PCB message containing 32 bits $m_{31}-m_0$ shall be transmitted in 96 symbol periods (m_0 first and m_{31} last). An R-MSG-PCB message containing $32 + NSCds$ bits $m_{31} + NSCds - m_0$ shall be transmitted in $96 + 3 \times NSCds$ symbol periods (m_0 first and $m_{31} + NSCds$ last). A zero bit shall be transmitted as three consecutive R-COMB symbols. A one bit shall be transmitted as three consecutive R-ICOMB symbols.

After the R-MSG-PCB message has been transmitted, a CRC shall be appended to the message. The 16 CRC bits shall be computed from the 32 or $32 + NSCds$ message m bits in the same way as the CRC bits are calculated for the C-MSG-FMT message.

The 16 bits c_0-c_{15} shall be transmitted in 48 symbol periods (c_0 first and c_{15} last) using the same modulation as used to transmit the message m .

The R-MSG-PCB state shall be followed by the R-REVERB1 state.

8.13.4 Transceiver training phase

See 8.13.4/G.992.3.

8.13.5 Channel analysis phase

See 8.13.5/G.992.3.

8.13.5.1 ATU-C channel analysis

See 8.13.5.1/G.992.3.

8.13.5.1.1 C-MSG1

The C-MSG1 state is of fixed length. In this state, the ATU-C shall transmit LEN_C-MSG1 C-REVERB or C-SEGUE symbols to modulate the C-MSG1 prefix, message and CRC. The C-MSG1 state shall be the first state in which the ATU-C transmits the cyclic prefix.

The C-MSG1 prefix, p , is defined by:

$$p = \{p_{31}, \dots, p_0\} = \{01010101\ 01010101\ 01010101\ 01010101\}$$

The 32 bits p_0 to p_{31} shall be transmitted in 32 symbol periods (p_0 first and p_{31} last). A zero bit shall be transmitted as a C-REVERB symbol. A one bit shall be transmitted as a C-SEGUE symbol.

The value LEN_C-MSG1 shall be defined as the length of the C-MSG1 prefix, message and CRC in bits. Table 8-13 lists the length of the C-MSG1 message summed over TPC-TC, PMS-TC and PMD layers. The TPS-TC, PMS-TC and PMD bits each correspond to an even number of octets.

Table 8-13/G.992.5 – C-MSG1 prefix, message and CRC length

Part of message	Length (bits or symbols)
Prefix	32
N_{pmd} (see Note)	160 or $160 + NSCds/4$
N_{pms}	32
N_{tps}	0
N_{msg}	192 or $192 + NSCds/4$
CRC	16
LEN_C-MSG1 (symbols)	240 or $240 + NSCds/4$
NOTE – Length depends on whether windowing is applied or not (see 8.5.3.2).	

The C-MSG1 message, m , is defined by:

$$m = \{tps_{N_{tps}-1}, \dots, tps_0, pms_{N_{pms}-1}, \dots, pms_0, pmd_{N_{pmd}-1}, \dots, pmd_0\} = \{m_{N_{msg}-1}, \dots, m_0\}$$

The C-MSG1 message conveys 3 sets of parameters, related to TPS-TC, PMS-TC and PMD configuration. TPS-TC parameters are conveyed in the bits $tps_{N_{tps}-1}$ to tps_0 and are defined in clause 6. PMS-TC parameters are conveyed in the bits $pms_{N_{pms}-1}$ to pms_0 and are defined in clause 7. PMD parameters are conveyed in the bits $pmd_{N_{pmd}-1}$ to pmd_0 and are defined in clause 8.

The N_{msg} bits m_0 – $m_{N_{msg}-1}$ shall be transmitted in N_{msg} symbol periods (m_0 first and $m_{N_{msg}-1}$ last), immediately following the prefix, and using the same modulation as used to transmit the prefix p .

After the C-MSG1 message has been transmitted, a CRC shall be appended to the message. The 16 CRC bits shall be computed from the $Nmsg$ message m bits (thus not including the prefix) in the same way as the CRC bits are calculated for the C-MSG-PCB message.

The 16 bits c_0 - c_{15} shall be transmitted in 16 symbol periods (c_0 first and c_{15} last) using the same modulation as used to transmit the message m .

The C-MSG1 state shall be followed by the C-REVERB5 state.

8.13.5.1.2 C-REVERB5

See 8.13.5.1.2/G.992.3.

8.13.5.1.3 C-SEGUE2

See 8.13.5.1.3/G.992.3.

8.13.5.1.4 C-MEDLEY

The C-MEDLEY state is of fixed length. In this state, the ATU-C shall transmit $LEN-MEDLEY$ symbols. The value $LEN-MEDLEY$ shall be the maximum of the CA-MEDLEYus and CA-MEDLEYds values indicated by the ATU-C and the ATU-R in the C-MSG1 and R-MSG1 messages respectively. The value $LEN-MEDLEY$ shall be a multiple of 512 and shall be less than or equal to 32256. The number of symbols transmitted in the C-MEDLEY state shall be equal to the number of symbols transmitted by the ATU-R in the R-MEDLEY state.

A C-MEDLEY symbol shall be defined depending on its symbolcount within the C-MEDLEY state. The first symbol transmitted in the C-MEDLEY state shall have symbolcount equal to zero. For each symbol transmitted in the C-MEDLEY state, the symbolcount shall be incremented.

The data pattern modulated onto each C-MEDLEY symbol shall be taken from one of the pseudo-random binary sequence (PRBS) defined by:

$$d_n = 1 \text{ for } n = 1 \text{ to } 9 \text{ and } d_n = d_{n-4} \oplus d_{n-9} \text{ for } n > 9$$

or

$$d_n = 1 \text{ for } n = 1 \text{ to } 14 \text{ and } d_n = d_{n-5} \oplus d_{n-11} \oplus d_{n-12} \oplus d_{n-14} \text{ for } n > 14$$

Support of the 14th order PRBS is optional for ATU-C and ATU-R. The 14th order PRBS shall be used if and only if the FMT-C-MEDLEYPRBS bit is set to 1 in both the C-MSG-FMT and R-MSG-FMT message respectively. The 9th order polynomial shall be used otherwise.

The C-MEDLEY symbol with symbolcount i shall modulate the $2 \times NSCds$ bits $d_{2 \times NSCds \times i + 1}$ to $d_{2 \times NSCds \times (i + 1)}$.

Bits shall be extracted from the PRBS in pairs. For each symbol transmitted in the C-MEDLEY state, $NSCds$ pairs ($2 \times NSCds$ bits) shall be extracted from the PRBS generator. The first extracted pair shall be modulated onto subcarrier 0 (so the bits are effectively ignored). The subsequent pairs are used to define the X_i and Y_i components for the subcarriers $i = 1$ to $NSCds - 1$, as defined in Table 8-36/G.992.3 for C-REVERB symbols. For the subcarriers $i = NSCds$ to $2 \times NSCds - 1$, the $X_i = Y_i = 0$.

While the ATU-C is in the C-MEDLEY state, the ATU-C and ATU-R may perform further training and SNR estimation.

The C-MEDLEY state shall be followed by the C-EXCHMARKER state.

8.13.5.1.5 C-EXCHMARKER

See 8.13.5.1.5/G.992.3.

8.13.5.2 ATU-R channel analysis

See 8.13.5.2/G.992.3.

8.13.6 Exchange phase

See 8.13.6/G.992.3.

8.13.6.1 ATU-C exchange

See 8.13.6.1/G.992.3.

8.13.6.1.1 C-MSG2

See 8.13.6.1.1/G.992.3.

8.13.6.1.2 C-REVERB6

The C-REVERB6 state is of variable length. In this state, the ATU-C shall transmit a minimum of $\text{MAX}(NSCds - NSCus - 10, 80)$ and a maximum of $\text{MAX}(NSCds - NSCus + 1990, 2000)$ C-REVERB symbols.

This state is a filler state to allow the ATU-C to receive (and decode) the complete R-MSG2 message.

If the ATU-R has transmitted R-REVERB symbols during the R-EXCHMARKER state, the ATU-C shall continue to transmit C-REVERB symbols until after the ATU-R transitioning to the R-REVERB6 state. Within 80 to 2000 symbols after the ATU-R transitioning to the R-REVERB6 state, the ATU-C shall transition to the next state.

If the ATU-R has transmitted R-SEGUE symbols during the R-EXCHMARKER state, the ATU-C shall continue to transmit C-REVERB symbols until after the ATU-R transitioning to the R-REVERB7 state. Within 80 to 2000 symbols after the ATU-R transitioning to the R-REVERB7 state, the ATU-C shall transition to the next state.

The C-REVERB6 state shall be followed by the C-SEGUE3 state.

8.13.6.1.3 C-SEGUE3

See 8.13.6.1.3/G.992.3.

8.13.6.1.4 C-PARAMS

See 8.13.6.1.4/G.992.3, with changing Table 8-14 as follows:

Table 8-14/G.992.5 – C-PARAMS message and CRC length

Part of message	Length (bits or symbols)
N_{pmd}	$96 + 32 \times NSC_{us}$
N_{pms}	224
N_{tps}	0
N_{msg}	$320 + 32 \times NSC_{us}$
CRC	16
$LEN_C-PARAMS$ (state length in symbols)	$\left\lceil \frac{336 + 32 \times NSC_{us}}{2 \times NSC_C-PARAMS} \right\rceil$
NOTE – $\lceil x \rceil$ denotes rounding to the higher integer.	

8.13.6.1.5 C-REVERB7

See 8.13.6.1.5/G.992.3.

8.13.6.1.6 C-SEGUE4

See 8.13.6.1.6/G.992.3.

8.13.6.2 ATU-R exchange

See 8.13.6.2/G.992.3.

8.13.6.2.1 R-MSG2

The R-MSG2 state is of fixed length. In the R-MSG2 state, the ATU-R shall transmit $NSC_{ds} + 16$ R-REVERB or R-SEGUE symbols to modulate the R-MSG2 message and CRC.

The R-MSG2 message, m , is defined by:

$$m = \{m_{NSC_{ds}-1}, \dots, m_0\}$$

The bit m_i shall be set to 1 to indicate that the ATU-C shall use subcarrier index i to modulate the C-PARAMS message. The bit m_i shall be set to 0 to indicate that the ATU-C shall not use subcarrier index i to modulate the C-PARAMS message. At least 4 subcarriers shall be used for modulation of the C-PARAMS message. The C-PARAM message will be transmitted at about 8 kbit/s times the number of subcarriers used for modulation of the message.

If the ATU-R has set the R-MSG-FMT message bit FMT-C-PILOT to 1, then the ATU-C modulates the C-TREF pilot tone with a fixed constellation point. In this case, the ATU-R shall not use the C-TREF pilot tone for modulation of the C-PARAMS message.

The bits $m_0 - m_{NSC_{ds}-1}$ shall be transmitted in NSC_{ds} symbol periods (m_0 first and $m_{NSC_{ds}-1}$ last). A zero bit shall be transmitted as an R-REVERB symbol. A one bit shall be transmitted as an R-SEGUE symbol.

After the R-MSG2 message has been transmitted, a CRC shall be appended to the message. The 16 CRC bits shall be computed from the NSC_{ds} message m bits in the same way as the CRC bits are calculated for the C-MSG-PCB message.

The 16 bits $c_0 - c_{15}$ shall be transmitted in 16 symbol periods (c_0 first and c_{15} last) using the same modulation as used to transmit the message m .

If the ATU-R has transmitted R-REVERB symbols during the R-EXCHMARKER state, the R-MSG2 state shall be followed by the R-REVERB6 state. If the ATU-R has transmitted R-SEGUE symbols during the R-EXCHMARKER state, the R-MSG2 state shall be followed by the R-REVERB7 state.

8.13.6.2.2 R-REVERB6

See 8.13.6.2.2/G.992.3.

8.13.6.2.3 R-SEGUE3

See 8.13.6.2.3/G.992.3.

8.13.6.2.4 R-PARAMS

See 8.13.6.2.4/G.992.3, changing Table 8-40/G.992.3 with Table 8-15:

Table 8-15/G.992.5 – R-PARAMS message and CRC length

Part of message	Length (bits or symbols)
<i>Npmd</i>	$96 + 32 \times NSCds$
<i>Npms</i>	224
<i>Ntps</i>	0
<i>Nmsg</i>	$320 + 32 \times NSCds$
CRC	16
<i>LEN_R-PARAMS</i> (state length in symbols)	$\left\lceil \frac{336 + 32 \times NSCds}{2 \times NSC_R-PARAMS} \right\rceil$
NOTE – $\lceil x \rceil$ denotes rounding to the higher integer.	

8.13.6.2.5 R-REVERB7

See 8.13.6.2.5/G.992.3.

8.13.6.2.6 R-SEGUE4

See 8.13.6.2.6/G.992.3.

8.13.7 Timing diagram of the initialization procedures

Figure 8-5 shows the timing diagram of the first part of the initialization procedures, from the G.994.1 phase up to the start of the Channel Analysis phase. Figures 8-6 to 8-9 show the second part of the Initialization procedures, from the end of the Channel Analysis Phase up to Showtime. These four timing diagrams represent the four cases resulting from whether the C-PARAMS and/or R-PARAMS states are included or not.

G.994.1		G.994.1		
≥ 512 ≤ 4204	C-QUIET1	≥ 512 and ≤ 2048 after both ATUs are in QUIET1	R-QUIET1	≥ 640 ≤ 4396
128	C-COMB1			
256	C-QUIET2	≤ 64	R-COMB1	128
1024 or 3872	C-COMB2		R-QUIET2	$\geq 64 + LEN_C-COMB2$ $\leq 714 + LEN_C-COMB2$
0 or 10	C-ICOMB1			
0 or 512	C-LINEPROBE			
≥ 256 ≤ 906	C-QUIET3	≤ 64	R-COMB2	256
			R-ICOMB1	0 or 10
			R-LINEPROBE	0 or 512
64	C-COMB3	≤ 64	R-QUIET3	≥ 266 $\leq 410 + 3 \times NSCus$
10	C-ICOMB2			
96	C-MSG-FMT			
96 or $96 + 3 \times NSCus$	C-MSG-PCB			
≥ 314 $\leq 474 + 3 \times NSCds$	C-QUIET4	≤ 80	R-COMB3	64
			R-ICOMB2	10
			R-MSG-FMT	96
			R-MSG-PCB	144 or $144 + 3 \times NSCds$
		≤ 80	R-REVERB1	272 or 592
$LEN_R-REVERB1$ $+ LEN_R-QUIET4 - 80$	C-REVERB1		R-QUIET4	≥ 0 ≤ 15872
≥ 512 ≤ 15872	C-TREF1		R-REVERB2	≥ 432 ≤ 15888
64	C-REVERB2	≤ 64	R-QUIET5 Last symbol may be shortened by n samples	≥ 1024 ≤ 16384
512	C-ECT			
≥ 448 ≤ 15936	C-REVERB3	≤ 64	R-REVERB3	64
576	C-TREF2/C-QUIET5		R-ECT	512
256 or 1024	C-REVERB4	Introduction of cyclic prefix	R-REVERB4	$\geq LEN_C-REVERB4$ $\leq LEN_C-REVERB4 + 80$
10	C-SEGUE1			R-SEGUE1
LEN_C-MSG1	C-MSG1		R-REVERB5	≥ 10 $\leq 196 + LEN_C-MSG1$
≥ 10 $\leq 218 + LEN_R-MSG1$	C-REVERB5	≤ 128	R-SEGUE2	10
			R-MSG1	LEN_R-MSG1
10	C-SEGUE2	≤ 80		

G.992.5_F8-5

Figure 8-5/G.992.5 – Timing diagram of the initialization procedure (part 1)

		C-MEDLEY starts 10 to 90 symbols after R-MEDLEY		
<i>LEN_MEDLEY</i>	C-MEDLEY		R-MEDLEY	<i>LEN_MEDLEY</i>
64	C-EXCHMARKER		R-EXCHMARKER	64
<i>NSCus+16</i>	C-MSG2		R-MSG2	<i>NSCds+16</i>
$\geq NSCds - NSCus - 10$ $\leq NSCds - NSCus + 1990$	C-REVERB6	≥ 80 ≤ 2000	R-REVERB6	≥ 80 ≤ 2000
10	C-SEGUE3	ATU-x transitions to x-REVERB7 state at end of x-PARAMS	R-SEGUE3	10
<i>LEN_C-PARAMS</i>	C-PARAMS		R-PARAMS	<i>LEN_R-PARAMS</i>
≥ 128	C-REVERB7	≥ 128 and ≤ 2048 after both ATUs are in REVERB7	R-REVERB7	≥ 128
10	C-SEGUE4		R-SEGUE4	10
	C-SHOWTIME		R-SHOWTIME	G.992.5_F8-6

Figure 8-6/G.992.5 – Timing diagram of the initialization procedure (part 2) with C-PARAMS and with R-PARAMS states

		C-MEDLEY starts 10 to 90 symbols after R-MEDLEY		
<i>LEN_MEDLEY</i>	C-MEDLEY		R-MEDLEY	<i>LEN_MEDLEY</i>
64	C-EXCHMARKER		R-EXCHMARKER	64
<i>NSCus+16</i>	C-MSG2		R-MSG2	<i>NSCds+16</i>
$\geq NSCds - NSCus + 38$ $\leq NSCds - NSCus + 2038$	C-REVERB7	≥ 128 ≤ 2048	R-REVERB7	≥ 128 ≤ 2048
10	C-SEGUE4		R-SEGUE4	10
	C-SHOWTIME		R-SHOWTIME	G.992.5_F8-7

Figure 8-7/G.992.5 – Timing diagram of the initialization procedure (part 2) without C-PARAMS and without R-PARAMS states

		C-MEDLEY starts 10 to 90 symbols after R-MEDLEY		
LEN_MEDLEY	C-MEDLEY		R-MEDLEY	LEN_MEDLEY
64	C-EXCHMARKER		R-EXCHMARKER	64
$NSCus+16$	C-MSG2		R-MSG2	$NSCds+16$
$\geq NSCds-NSCus-10$ $\leq NSCds-NSCus+1990$	C-REVERB6	≥ 80 ≤ 2000	R-REVERB7	$\geq 218+LEN_C-PARAMS$ $\leq 4058+LEN_C-PARAMS$
10	C-SEGUE3			
$LEN_C-PARAMS$	C-PARAMS			
≥ 128 ≤ 2048	C-REVERB7	≥ 128 ≤ 2048		
10	C-SEGUE4		R-SEGUE4	10
	C-SHOWTIME		R-SHOWTIME	

G.992.5_F8-8

Figure 8-8/G.992.5 – Timing diagram of the initialization procedure (part 2) with C-PARAMS and without R-PARAMS states

		C-MEDLEY starts 10 to 90 symbols after R-MEDLEY		
LEN_MEDLEY	C-MEDLEY		R-MEDLEY	LEN_MEDLEY
64	C-EXCHMARKER		R-EXCHMARKER	64
$NSCus+16$	C-MSG2		R-MSG2	$NSCds+16$
$\geq NSCds-NSCus+128$ $+LEN_R-PARAMS$ $\leq NSCds-NSCus+4048$ $+LEN_R-PARAMS$	C-REVERB7		R-REVERB6	≥ 80 ≤ 2000
			R-SEGUE3	10
			R-PARAMS	$LEN_R-PARAMS$
		≥ 128 ≤ 2048	R-REVERB7	≥ 128 ≤ 2048
10	C-SEGUE4		R-SEGUE4	10
	C-SHOWTIME		R-SHOWTIME	

G.992.5_F8-9

Figure 8-9/G.992.5 – Timing diagram of the initialization procedure (part 2) without C-PARAMS and with R-PARAMS states

8.14 Short initialization procedures

A short initialization sequence is defined to allow the ATUs to quickly enter Showtime from a L3 power management state or as a fast recovery procedure from changing of line conditions during Showtime. The short initialization sequence shall be optional for both ATU-C and ATU-R (with indication in ITU-T Rec. G.994.1, see 8.13.2). If the short initialization sequence is supported, the ATU should also support unbalanced bitswap (i.e., type 3 On-Line Reconfiguration with restriction to change b_i , g_i and L_p only, see 9.4.1.1).

The state diagram of the short sequence shall be the same as the one shown in Figures 8-5 to 8-9, with the exception of the entry procedures which shall be as depicted in Figures 8-10 and 8-11. Figure 8-10 shows the entry procedure for an ATU-C initiated short initialization. The ATU-C shall keep transmitting 128 symbols of C-COMB1 followed by 256 symbols of silence (C-QUIET2) until either the ATU-R responds with R-COMB1 during one of the C-QUIET2 states or a vendor discretionary timeout C-T1 is reached. If the short initialization is used as a fast recovery procedure from showtime, the ATU-R should reply to the first transmission of the C-COMB initialization signal.

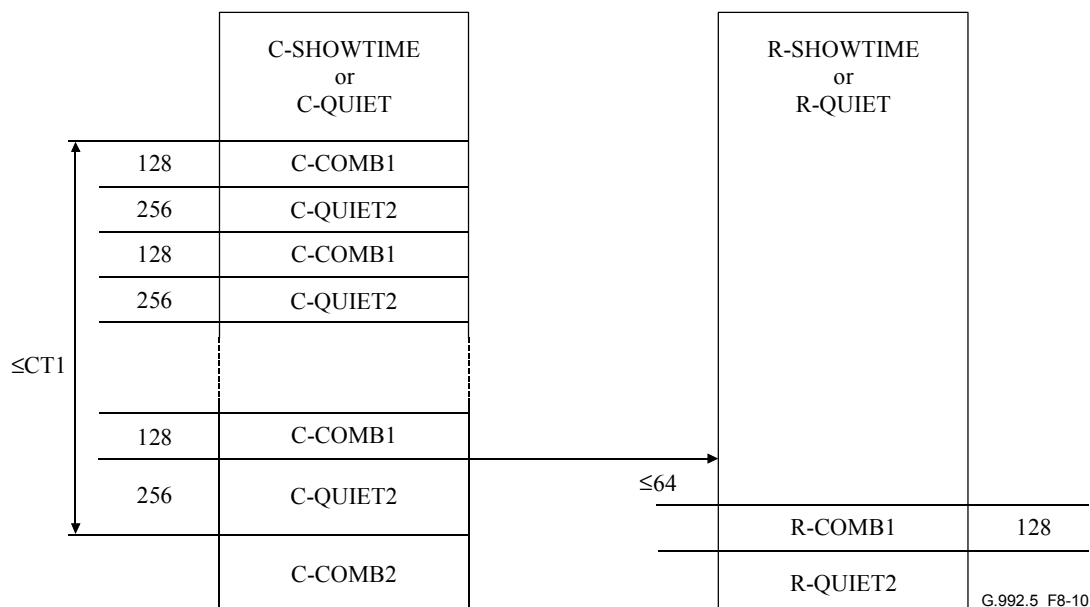

Figure 8-10/G.992.5 – Timing diagram of the entry into the short initialization procedure, ATU-C initiated

Figure 8-11 shows the entry procedure for an ATU-R initiated short initialization. The ATU-R shall keep transmitting 128 symbols of R-COMB1 followed by 256 symbols of silence (R-QUIET2) until either the ATU-C responds with C-COMB2 during one of the R-QUIET2 states or a vendor discretionary timeout R-T1 is reached. If the short initialization is used as a fast recovery procedure from showtime, the ATU-C should reply to the first transmission of the R-COMB initialization signal.

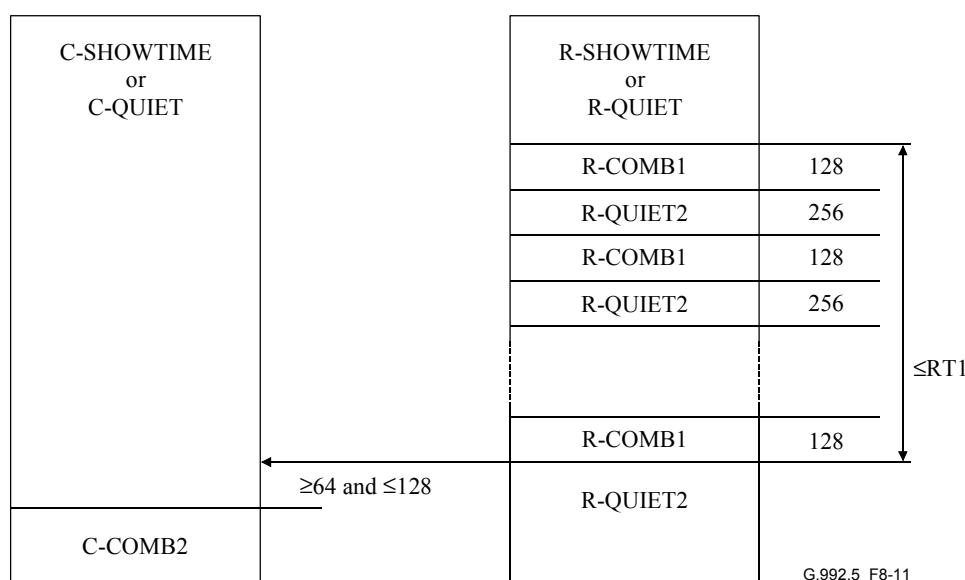

Figure 8-11/G.992.5 – Timing diagram of the entry into the short initialization procedure, ATU-R initiated

The short initialization procedure may be used for the link state transition from the L3 state to the L0 state (see 9.5.3/G.992.3). Fast error recovery (during the L0 or L2 link state) is through the short initialization procedure. At the start of the short initialization procedure, the ADSL link state shall be changed to the L3 state. When the ATU reaches the Showtime state through the short initialization procedure, the ADSL link shall be in the L0 state (see Figure 9-5/G.992.3).

The short initialization procedure should be completed within 3 s. However, to meet this requirement, proper time budget balancing between ATU-C and ATU-R is required. Table 8-16 lists recommended time budgets for the variable portions of each ATU initialization sequence. Figures 8-12 and 8-13 show the recommended timing diagram for the short initialization procedure.

Table 8-16/G.992.5 – Recommended duration for variable portions of the initialization sequence

ATU state	Recommended duration (symbols)	Note
C-MSG-PCB	=96	No C-BLACKOUT bits included (last previous exchanged BLACKOUT bits remain valid)
R-MSG-PCB	=144	No R-BLACKOUT bits included (last previous exchanged BLACKOUT bits remain valid)
R-REVERB1	=272	
R-QUIET4	=0	ATU-C hybrid fine tuning state is skipped
C-TREF1	≤1024	Faster upstream channel estimation, less precise timing and no ATU-R hybrid fine tuning
R-QUIET5	=1024	
C-REVERB3	=512 ± 64	Faster downstream channel estimation and equalizer training
C-REVERB4	=256	
C-MEDLEY	≤1024	Less accurate SNR estimation
R-MEDLEY	≤1024	Less accurate SNR estimation

Table 8-16/G.992.5 – Recommended duration for variable portions of the initialization sequence

ATU state	Recommended duration (symbols)	Note
C-REVERB6	≤ 120	Limit through faster and simpler bit allocation algorithm
R-REVERB6	≤ 120	Limit through faster and simpler bit allocation algorithm

1024 or 3872	C-COMB2			
0 or 10	C-ICOMB1			
0 or 512	C-LINEPROBE			
			≤ 64	
≥ 256 ≤ 906	C-QUIET3			
				R-QUIET2
				$\geq 64 + LEN_C-COMB2$ $\leq 714 + LEN_C-COMB2$
				R-COMB2
				256
				R-COMB1
				0 or 10
				R-LINEPROBE
				0 or 512
			≤ 64	
64	C-COMB3			
10	C-ICOMB2			
96	C-MSG-FMT			
96	C-MSG-PCB			
				R-QUIET3
				≥ 266 ≤ 410
			≤ 80	
≥ 314 ≤ 1242	C-QUIET4			
				R-COMB3
				64
				R-ICOMB2
				10
				R-MSG-FMT
				96
				R-MSG-PCB
				144
			≤ 80	
192	C-REVERB1			R-REVERB1
				272
≥ 512 ≤ 1024	C-TREF1			
				R-REVERB2
				≥ 432 ≤ 1088
			≤ 64	
64	C-REVERB2			
512	C-ECT			
				R-QUIET5
				Last symbol may be shortened by n samples
				1024
≥ 448 ≤ 576	C-REVERB3			
			≤ 64	
				R-REVERB3
				64
576	C-TREF2/C-QUIET5			
				R-ECT
				512
256	C-REVERB4			
				R-REVERB4
				≥ 256 ≤ 336
10	C-SEGUE1			
				R-SEGUE1
				10
LEN_C-MSG1	C-MSG1			
				R-REVERB5
				≥ 10 $\leq 196 + LEN_C-MSG1$
			≤ 128	
≥ 10 $\leq 218 + LEN_R-MSG1$	C-REVERB5			
				R-SEGUE2
				10
				R-MSG1
				LEN_R-MSG1
			≤ 80	
10	C-SEGUE2			

G.992.5_F8-12

Figure 8-12/G.992.5 – Timing diagram of the short initialization procedure (part 1)

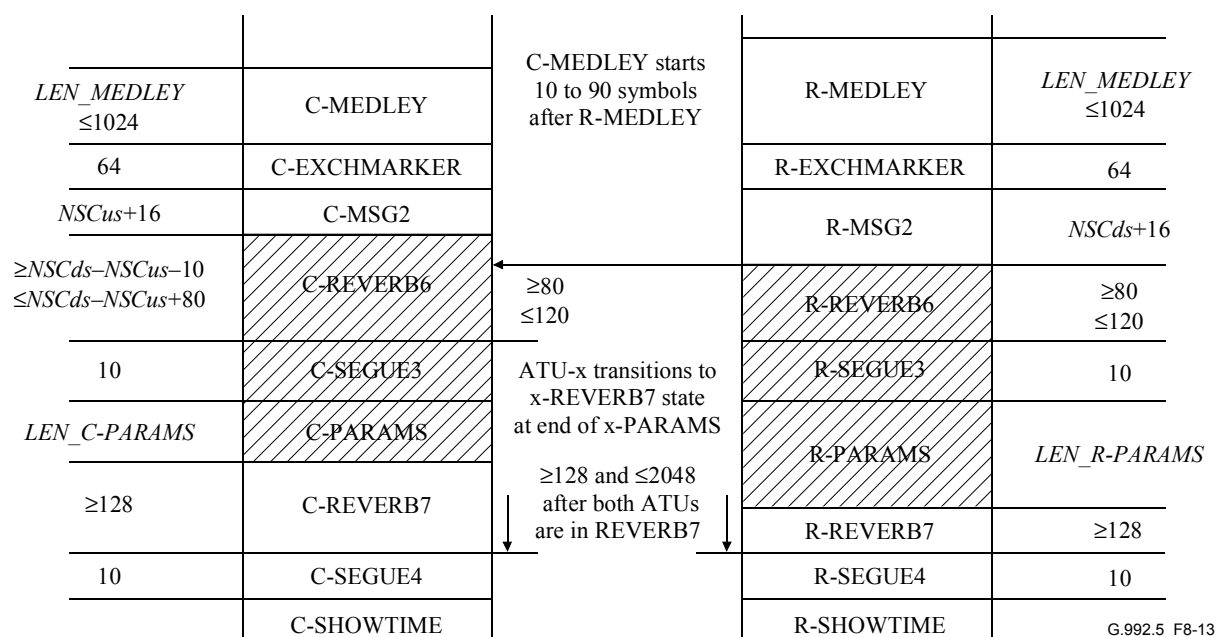

Figure 8-13/G.992.5 – Timing diagram of the short initialization procedure (part 2)

8.15 Loop diagnostics mode procedures

See 8.15/G.992.3.

8.15.1 Overview

See 8.15.1/G.992.3.

8.15.2 Channel discovery phase

See 8.15.2/G.992.3.

8.15.2.1 ATU-C channel discovery phase

The sequence of states in the Loop Diagnostics Mode shall be the same as for the Initialization sequence (defined in 8.13.3.1). Each state shall have fixed duration in Loop Diagnostics Mode, as shown in the Loop Diagnostics Mode timing diagram in Figure 8-14.

The signals transmitted during each of the states in the Loop Diagnostics Mode shall be the same as for the Initialization sequence (defined in 8.13.3.1).

The states C-ICOMB1 and C-LINEPROBE states and the C-BLACKOUT bits shall be included during an Initialization in Loop Diagnostics Mode.

The C-MSG-FMT message shall be as defined in Table 8-17.

Table 8-17/G.992.5 – Bit definition for the C-MSG-FMT message

Bit index	Parameter	Definition
9..0		Reserved, set to 0
10	FMT-C-MEDLEYPRBS	See Table 8-7
15..11		Reserved, set to 0

The C-MSG-PCB message shall be as defined in Table 8-18.

Table 8-18/G.992.5 – Bit definition for the C-MSG-PCB message

Bit index	Parameter	Definition
5..0	C-MIN_PCB_DS	See Table 8-27/G.992.3
11..6	C-MIN_PCB_US	See Table 8-27/G.992.3
13..12	HOOK_STATUS	See Table 8-27/G.992.3
15..14		Reserved, set to 0
<i>NSCus</i> + 15..16	C-BLACKOUT	See Table 8-27/G.992.3
<i>NSCus</i> + 23.. <i>NSCus</i> + 16	Pass/Fail	Success or Failure Cause indication of last previous initialization
<i>NSCus</i> + 31.. <i>NSCus</i> + 24	Last_TX_State	Last transmitted state of last previous initialization

The Pass/Fail bits shall contain a Success or Failure Cause indication. The possible indications and their coding shall be as defined in Table 8-19. If the initialization in loop diagnostics mode is immediately following the ATU-C power-up, information about the last previous initialization may not be available. In that case, a successful last previous initialization shall be indicated.

Table 8-19/G.992.5 – Success and Failure Cause indications

Value (higher bit index left)	Definition
1111 1111	Successful
0001 0001	Failed – Insufficient capacity
0010 0010	Failed – CRC error in one of the received messages
0100 0100	Failed – Time out exceeded
1000 1000	Failed – Unexpected received message content
0000 0000	Failed – Cause unknown
Other	Reserved

The Last_TX_State bits shall contain the index of the last ATU-C state that was successful transmitted during the last previous initialization. The index of the ATU-C state shall be represented by an 8-bit integer value from 0 (G.994.1 phase) and 1 (C-QUIET1) to 31 (C-SEGUE4) and 32 (C-SHOWTIME). The states shall be numbered in the order transmitted in time, as shown in the timing diagrams in Figures 8-14 and 8-15. The states that can be optionally omitted shall also be counted when calculating the index of a state. For example, the index of C-QUIET3 shall always be 7 regardless of whether the C-ICOMB1 and C-LINEPROBE states are included or not. In case the first octet of C-MSG-PCB indicates a successful initialization, this second octet shall encode the index of the last state, i.e. the index of C-SHOWTIME.

An addition of a CRC and the bit transmission order for the C-MSG-FMT and C-MSG-PCB messages shall be as defined for the Initialization sequence in 8.13.3.1. However, the message and CRC bits shall be transmitted with 8 symbols per bit modulation, where a zero bit shall be transmitted as 8 consecutive C-COMB symbols and a one bit shall be transmitted as 8 consecutive C-ICOMB symbols. This will make the transmission more robust against misdetection of the time marker transitions that precede these messages.

8.15.2.2 ATU-R channel discovery phase

The sequence of states in the Loop Diagnostics Mode shall be the same as for the Initialization sequence (defined in 8.13.3.2). Each state shall have fixed duration in Loop Diagnostics Mode, as shown in the Loop Diagnostics Mode timing diagram in Figure 8-14.

The signals transmitted during each of the states in the Loop Diagnostics Mode shall be the same as for the Initialization sequence (defined in 8.13.3.2).

The states R-ICOMB1 and R-LINEPROBE states and the R-BLACKOUT bits shall be included during an Initialization in Loop Diagnostics Mode.

The R-MSG-FMT message shall be as defined in Table 8-20.

Table 8-20/G.992.5 – Bit definition for the R-MSG-FMT message

Bit index	Parameter	Definition
7..0		Reserved, set to 0
8	FMT-C-TREF2	See Table 8-31/G.992.3
9	FMT-C-PILOT	See Table 8-31/G.992.3
10	FMT-C-MEDLEYPRBS	See Table 8-31/G.992.3
15..11		Reserved, set to 0

The R-MSG-PCB message shall be as defined in Table 8-21.

Table 8-21/G.992.5 – Bit definition for the R-MSG-PCB message

Bit index	Parameter	Definition
5..0	R-MIN_PCB_DS	See Table 8-32/G.992.3
11..6	R-MIN_PCB_US	See Table 8-32/G.992.3
13..12	HOOK_STATUS	See Table 8-32/G.992.3
15..14		Reserved, set to 0
26..16	C-PILOT	See Table 8-32/G.992.3
31..27		Reserved, set to 0
31 + NSCds..32	R-BLACKOUT	See Table 8-32/G.992.3
39 + NSCds..32 + NSCds	Pass/Fail	Success or Failure Cause indication of last previous initialization
47 + NSCds..40 + NSCds	Last_TX_State	Last transmitted state of last previous initialization

The Pass/Fail bits shall contain a Success or Failure Cause indication. The possible indications and their coding shall be as defined for the ATU-C in Table 8-19. If the initialization in loop diagnostics mode is immediately following the ATU-R power-up or self test, information about the last previous initialization may not be available. In that case, a successful last previous initialization shall be indicated.

The Last_TX_State bits shall contain the index of the last ATU-R state that was successfully transmitted during the last previous initialization. The index of the ATU-R state shall be represented by an 8-bit integer value from 0 (G.994.1 phase) and 1 (R-QUIET1) to 30 (R-SEGUE4) and 31 (R-SHOWTIME). The states shall be numbered in the order transmitted in time, as shown in the timing diagrams in Figures 8-14 and 8-15. The states that can be optionally omitted shall also be

counted when calculating the index of a state. For example, the index of R-QUIET3 shall always be 7 regardless of whether the R-ICOMB1 and R-LINEPROBE states are included or not. In case the first octet of the C-MSG-PCB message indicates a successful initialization, this second octet shall encode the index of the last state, i.e., the index of R-SHOWTIME.

The addition of a 16-bit CRC and the bit transmission order for the R-MSG-FMT and R-MSG-PCB messages shall be as defined for the Initialization sequence in 8.13.3.2. However, the bits shall be transmitted with 8 symbols per bit modulation, where a zero bit shall be transmitted as 8 consecutive R-COMB symbols and a one bit shall be transmitted as 8 consecutive R-ICOMB symbols. This will make the transmission more robust against misdetection of the time marker transitions that precede these messages.

8.15.3 Transceiver training phase

See 8.15.3/G.992.3.

8.15.4 Channel analysis phase

See 8.15.4/G.992.3.

8.15.5 Exchange phase

See 8.15.5/G.992.3.

8.15.5.1 ATU-C exchange phase

See 8.15.5.1/G.992.3.

8.15.5.2 ATU-R exchange phase

See 8.15.5.2/G.992.3.

8.15.5.2.1 Channel information bearing messages

In the loop diagnostics mode, the ATU-R shall send $(1 + NSCds/32)$ messages to the ATU-C: R-MSGx-LD, numbered from $x = 1$ to $1 + NSCds/32$. These messages contain the downstream test parameters defined in 8.15.1.

The information fields of the different messages shall be as shown in Tables 8-22 to 8-26.

Table 8-22/G.992.5 – Format of the R-MSG1-LD message

Octet Nr [i]	Information	Format message bits [$8 \times i + 7$ to $8 \times i + 0$]
0	Sequence number	[0000 0001]
1	Reserved	[0000 0000]
2	Hlin scale (LSB)	[xxxx xxxx], bits 7 to 0
3	Hlin scale (MSB)	[xxxx xxxx], bits 15 to 8
4	LATN (LSB)	[xxxx xxxx], bits 7 to 0
5	LATN (MSB)	[0000 00xx], bits 9 and 8
6	SATN (LSB)	[xxxx xxxx], bits 7 to 0
7	SATN (MSB)	[0000 00xx], bits 9 and 8
8	SNRM (LSB)	[xxxx xxxx], bits 7 to 0
9	SNRM (MSB)	[0000 00xx], bits 9 and 8
10	ATTNDR (LSB)	[xxxx xxxx], bits 7 to 0
11	ATTNDR	[xxxx xxxx], bits 15 to 8
12	ATTNDR	[xxxx xxxx], bits 23 to 16

Table 8-22/G.992.5 – Format of the R-MSG1-LD message

Octet Nr [i]	Information	Format message bits [$8 \times i + 7$ to $8 \times i + 0$]
13	<i>ATTNDR</i> (MSB)	[xxxx xxxx], bits 31 to 24
14	Far-end <i>ACTATP</i> (LSB)	[xxxx xxxx], bits 7 to 0
15	Far-end <i>ACTATP</i> (MSB)	[ssss sxxx], bits 9 and 8

Table 8-23/G.992.5 – Format of the Hlin(i) R-MSGx-LD message

Octet Nr [i]	Information	Format message bits [$8 \times i + 7$ to $8 \times i + 0$]
0	Sequence number	[xxxx xxxx] (as 8-bit unsigned integer)
1	Reserved	[0000 0000]
2	Hlin($64 \times k$) real (LSB)	[xxxx xxxx], bits 7 to 0
3	Hlin($64 \times k$) real (MSB)	[xxxx xxxx], bits 15 to 8
4	Hlin($64 \times k$) imag (LSB)	[xxxx xxxx], bits 7 to 0
5	Hlin($64 \times k$) imag (MSB)	[xxxx xxxx], bits 15 to 8
..
254	Hlin($64 \times k + 63$) real (LSB)	[xxxx xxxx], bits 7 to 0
255	Hlin($64 \times k + 63$) real (MSB)	[xxxx xxxx], bits 15 to 8
256	Hlin($64 \times k + 63$) imag (LSB)	[xxxx xxxx], bits 7 to 0
257	Hlin($64 \times k + 63$) imag (MSB)	[xxxx xxxx], bits 15 to 8
NOTE – For each of the values $k = 0$ to $NSCds/64 - 1$, a single R-MSGx-LD message shall be transmitted, with sequence number $x = 2 + k$.		

Table 8-24/G.992.5 – Format of the Hlog(i) R-MSGx-LD message

Octet Nr [i]	Information	Format
0	Sequence number	[xxxx xxxx] (as 8-bit unsigned integer)
1	Reserved	[0000 0000]
2	Hlog($128 \times k$) (LSB)	[xxxx xxxx], bits 7 to 0
3	Hlog($128 \times k$) (MSB)	[0000 00xx], bits 9 and 8
..
256	Hlog($128 \times k + 127$) (LSB)	[xxxx xxxx], bits 7 to 0
257	Hlog($128 \times k + 127$) (MSB)	[0000 00xx], bits 9 and 8
NOTE – For each of the values $k = 0$ to $NSCds/128 - 1$, a single R-MSGx-LD message shall be transmitted, with sequence number $x = NSCds/64 + 2 + k$.		

Table 8-25/G.992.5 – Format of the QLN(i) R-MSGx-LD message

Octet Nr [i]	Information	Format message bits [$8 \times i + 7$ to $8 \times i + 0$]
0	Sequence number	[xxxx xxxx] (as 8-bit unsigned integer)
1	Reserved	[0000 0000]
2	QLN($256 \times k$)	[xxxx xxxx], bits 7 to 0
..
257	QLN($256 \times k + 255$)	[xxxx xxxx], bits 7 to 0
NOTE – For each of the values $k = 0$ to $NSCds/256 - 1$, a single R-MSGx-LD message shall be transmitted, with sequence number $x = 3 \times NSCds/128 + 2 + k$.		

Table 8-26/G.992.5 – Format of the R-MSG9-LD message

Octet Nr [i]	Information	Format message bits [$8 \times i + 7$ to $8 \times i + 0$]
0	Sequence number	[xxxx xxxx] (as 8-bit unsigned integer)
1	Reserved	[0000 0000]
2	SNR($256 \times k$)	[xxxx xxxx], bits 7 to 0
..
257	SNR($256 \times k + 255$)	[xxxx xxxx], bit 7 to 0
NOTE – For each of the values $k = 0$ to $NSCds/256 - 1$, a single R-MSGx-LD message shall be transmitted, with sequence number $x = 7 \times NSCds/256 + 2 + k$.		

The messages shall be transmitted in order of ascending octet number (i.e., the sequence number shall be transmitted first) and each octet shall be transmitted LSB first.

The addition of a 16-bit CRC and the bit transmission order for the R-MSGx-LD messages shall be as defined for the Initialization sequence in 8.13. However, the message and CRC bits shall be transmitted with 8 symbols per bit modulation, where a zero bit shall be transmitted as eight consecutive R-REVERB symbols and a one bit shall be transmitted as eight consecutive R-SEGUE symbols. The resulting state duration (needed to transmit the message and CRC) is shown in Table 8-27.

Table 8-27/G.992.5 – ATU-R loop diagnostics state durations

State	Duration (symbols)
R-MSG1-LD	1152
R-MSG _x -LD with $x > 1$	16640

The resulting number of symbols needed to transmit each of the messages and CRC is shown in the Loop Diagnostics timing diagrams in Figures 8-14 and 8-15.

8.15.5.2.2 Message flow, acknowledgement and retransmission

See 8.15.2.2/G.992.3.

8.15.6 Timing diagram of the loop diagnostics procedures

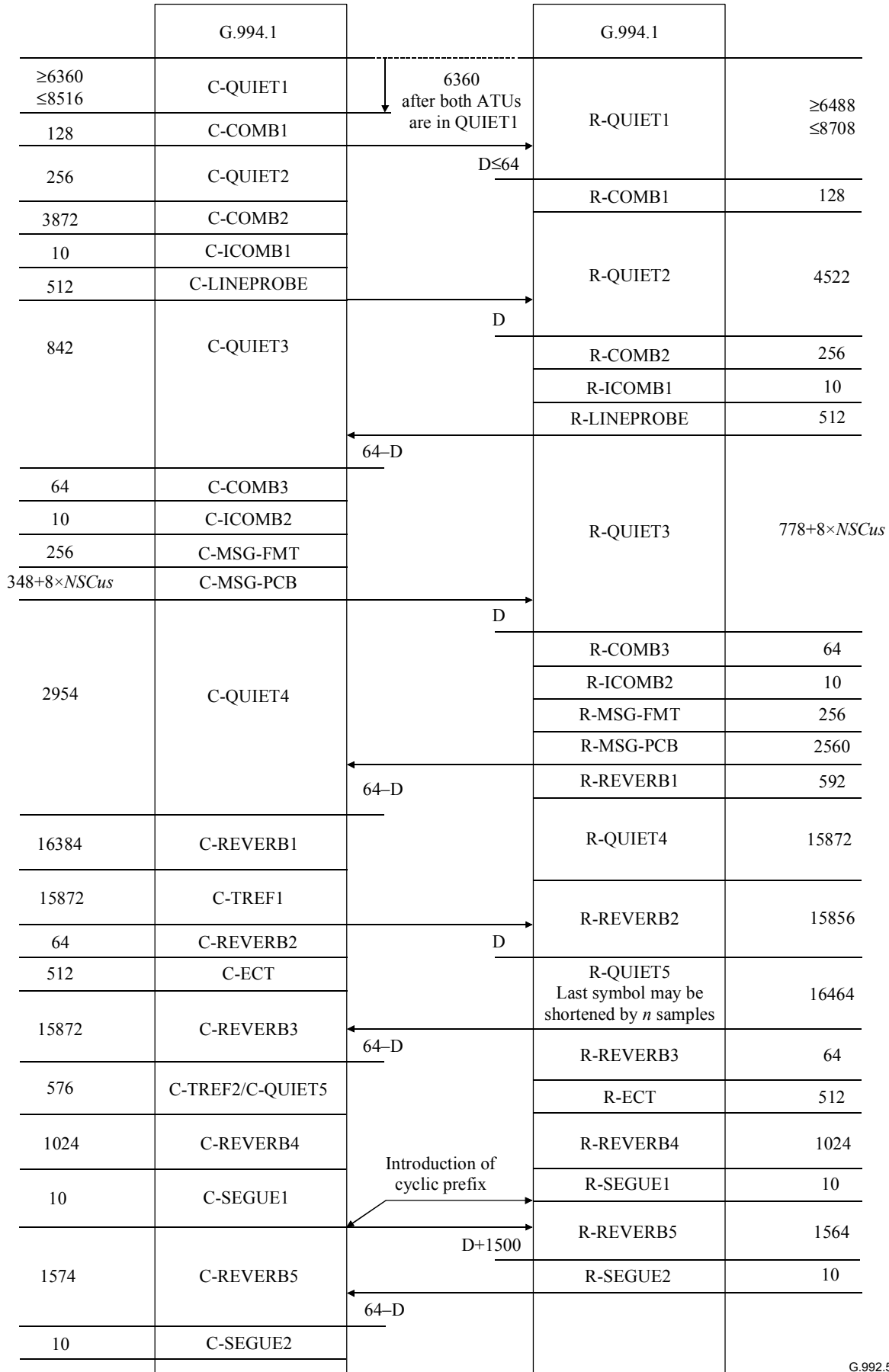

G.992.5_F8-14

Figure 8-14/G.992.5 – Loop diagnostics timing diagram (part 1)

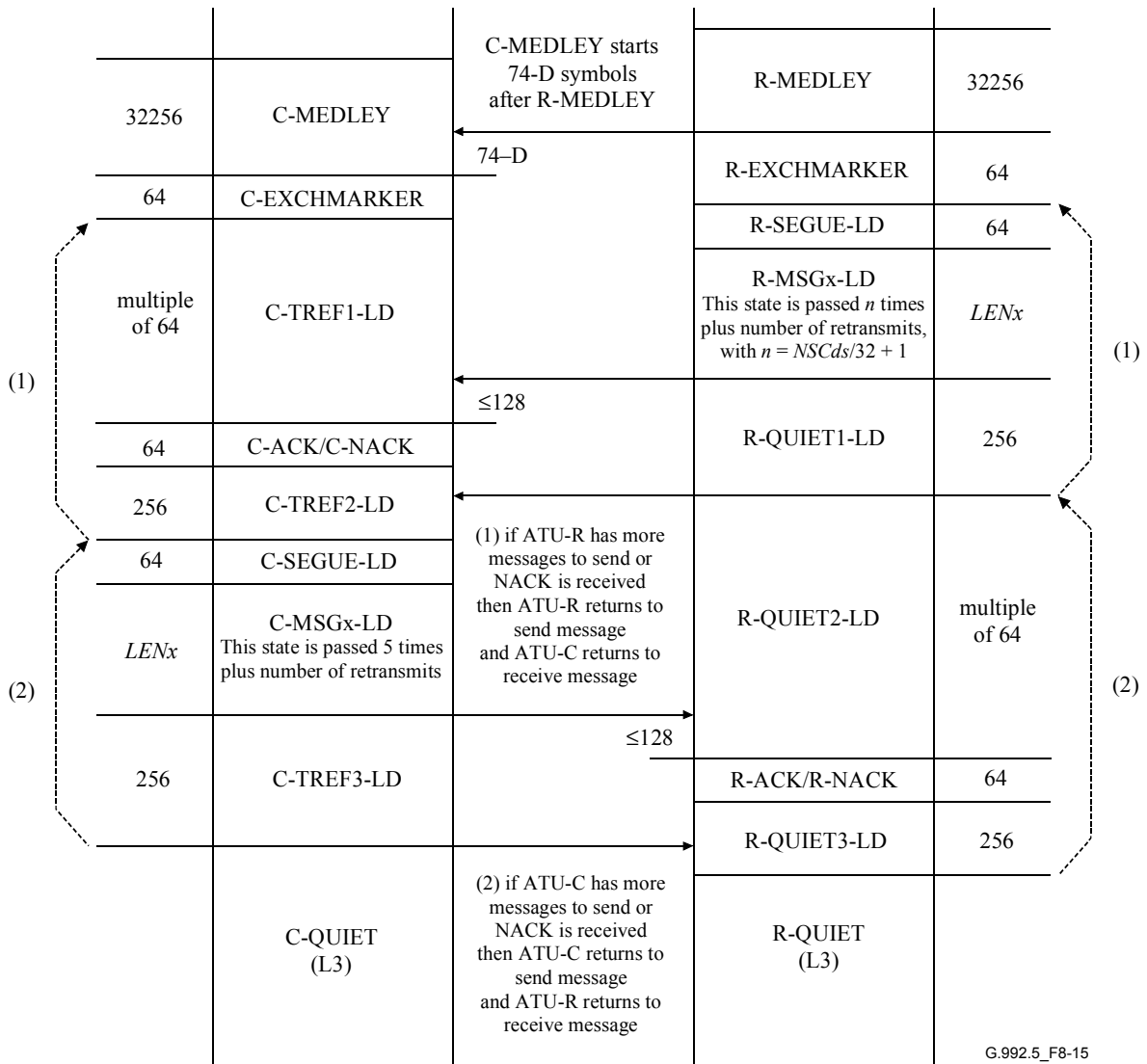

Figure 8-15/G.992.5 – Loop diagnostics timing diagram (part 2)

8.16 On-line reconfiguration of the PMD function

See 8.16/G.992.3.

8.17 Power management in the PMD function

See 8.17/G.992.3.

9 Management Protocol Specific Transmission Convergence (MPS-TC) functions

See clause 9/G.992.3.

9.1 Transport functions

See 9.1/G.992.3.

9.2 Additional functions

See 9.2/G.992.3.

9.3 Block interface signals and primitives

See 9.3/G.992.3.

9.4 Management plane procedures

See 9.4/G.992.3.

9.4.1 Commands

See 9.4.1/G.992.3.

9.4.1.1 On-line reconfiguration command

The on-line reconfiguration commands shall be used to control certain on-line dynamic behaviour defined in this clause. Additional information is provided on this dynamic behaviour in clause 10. On-line reconfiguration commands may be initiated by either ATU as shown in Table 9-1. However, the initiator is only provided with means to effect changes in its receiver and the corresponding transmitter. The responding ATU may use the on-line reconfiguration commands shown in Table 9-2 or may positively acknowledge the initiator's request by transmitting a line signal corresponding to the PMD.Synchflag primitive. The on-line reconfiguration commands shall consist of multiple octets. The first octet shall be the on-line reconfiguration command designator shown in Table 9-2/G.992.3. The remaining octets shall be as shown in Tables 9-1, 9-2 and 9-3. The octets shall be sent using the format described in 7.8.2.3/G.992.3 and using the protocol described in 7.8.2.4.

Table 9-1/G.992.5 – On-line reconfiguration commands transmitted by the initiating receiver

Message length (Octets)	Element name (Command)
$4 + 4 \times N_f$	04 ₁₆ Request Type 1 followed by: 2 octets for the number of subcarriers N_f $4 \times N_f$ octets describing subcarrier parameter field for each subcarrier
$4 + 2 \times N_{LP} + N_{BC} + 4 \times N_f$	05 ₁₆ Request Type 2 followed by: $2 \times N_{LP}$ octets containing new L_p values for the N_{LP} enabled latency paths, N_{BC} octets containing new $B_{p,n}$ values for the N_{BC} enabled frame bearers, 2 octets for the number of carriers N_f $4 \times N_f$ octets describing subcarrier parameter field for each subcarrier
$4 + 2 \times N_{LP} + N_{BC} + 4 \times N_f$	06 ₁₆ Request Type 3 followed by: $2 \times N_{LP}$ octets containing new L_p values for the N_{LP} enabled latency paths, N_{BC} octets containing new $B_{p,n}$ values for the N_{BC} enabled frame bearers, 2 octets for the number of carriers N_f $4 \times N_f$ octets describing subcarrier parameter field for each subcarrier All other octet values are reserved by the ITU-T.

**Table 9-2/G.992.5 – On-line reconfiguration commands transmitted
by the responding transmitter**

Message length (Octets)	Element name (Command)
3	81 ₁₆ Defer Type 1 Request followed by: 1 octet for reason code
3	82 ₁₆ Reject Type 2 Request followed by: 1 octet for reason code
3	83 ₁₆ Reject Type 3 Request followed by: 1 octet for reason code
	All other octet values are reserved by the ITU-T.

An ATU may request only changes in its receiver operation. Changes may be requested concurrently by both ATUs; each transaction shall follow the procedures described in this clause. An ATU-R shall not initiate an OLR command if it has transmitted an L2 Grant command and is awaiting a response.

A subcarrier parameter field contains 4 octets formatted as [0000 0ccc cccc cccc gggg gggg gggg bbbb]. The carrier index i (11 bits), the g_i (12 bits) and the b_i (4 bits). The carrier index shall be the three least significant bits of the first octet and the second octet of the subcarrier field. The least significant bits of the carrier index i shall be contained in the second octet. The g_i shall be contained in the third octet and the four most significant bits of the fourth octet. The least significant bits of g_i shall be contained in the fourth octet. The b_i shall be the least significant 4 bits of the fourth octet.

Type 1 and Type 2 shall be sent such that the PMD parameter L is unchanged. If an ATU implements the optional short PMD initialization sequence, then the ATU should also implement Type 3 OLR operations changing b_i , g_i and L_p .

Reason codes associated with the OLR commands are shown in Table 9-3.

Table 9-3/G.992.5 – Reason codes for OLR commands

Reason	Octet value	Applicable to defer Type 1	Applicable to reject Type 2	Applicable to reject Type 3
Busy	01 ₁₆	X	X	X
Invalid parameters	02 ₁₆	X	X	X
Not enabled	03 ₁₆		X	X
Not supported	04 ₁₆		X	X

Upon transmitting an on-line reconfiguration command, the initiator shall await a response to the command, either an on-line reconfiguration command for defer or reject or the line signal corresponding to the PMD.Synchflag primitive. If the response is not received within the timeout of the high priority overhead messages displayed in Table 7-17/G.992.3, the initiator shall abandon the current on-line reconfiguration command. A new command may be initiated immediately, including an identical request.

Upon receipt of an on-line reconfiguration command, the responder shall respond with either an on-line reconfiguration command for defer or reject or the line signal corresponding to the PMD.Synchflag primitive. In the case of sending the line signal corresponding to the PMD.Synchflag primitive, the ATU shall reconfigure the effected PMD, PMS-TC, and TPS-TC functions as described in the reconfiguration clauses describing those functions. In the case of defer

or reject, the receiver shall supply a reason code from the following: 01₁₆ for busy, 02₁₆ for invalid parameters, 03₁₆ for not enabled, and 04₁₆ for not supported. The reason codes 01₁₆ and 02₁₆ shall be the only codes used in an on-line reconfiguration command for defer type 1 request.

Upon receipt of a line signal corresponding to the PMD.Synchflag primitive, the initiator shall reconfigure the effected PMD, PMS-TC, and TPS-TC functions as described in the reconfiguration clauses describing those functions. If an on-line reconfiguration command for defer or reject is received, the initiator shall abandon the current on-line reconfiguration command. A new command may be initiated immediately, including an identical request.

9.4.1.2 eoc commands

See 9.4.1.2/G.992.3.

9.4.1.3 Time commands

See 9.4.1.3/G.992.3.

9.4.1.4 Inventory command

See 9.4.1.4/G.992.3.

9.4.1.5 Control value read commands

See 9.4.1.5/G.992.3.

9.4.1.6 Management counter read commands

See 9.4.1.6/G.992.3.

9.4.1.7 Power management commands

The power management command shall be used to propose power management transitions from one link state to another as described in the Power Management clause. The power management command may be initiated by either ATU as prescribed in the Power Management clause as shown in Table 9-4. The responses shall be using the command shown in Table 9-5. The power management command is variable in length. The first octet shall be power management command designator shown in Table 9-3/G.992.3. The remaining octets shall be as shown in Table 9-4. The power management response commands are variable in length. The first octet shall be power management command designator shown in Table 9-3/G.992.3. The second shall be as shown in Table 9-5. The octets shall be sent using the format described in 7.8.2.3/G.992.3 and using the protocol described in 7.8.2.4/G.992.3.

**Table 9-4/G.992.5 – Power management commands transmitted
by the initiating ATU**

Message length (octets)	Element name (Command)
3	01 ₁₆ Simple Request followed by: 1 octet for the new proposed link state
4 + 4 × N_{LP}	02 ₁₆ L2 Request followed by: 1 octet for minimum $PCBds$ value (dB) 1 octet for maximum $PCBds$ value (dB); 2 × N_{LP} octets containing maximum L_p values for the N_{LP} enabled latency paths; 2 × N_{LP} octets containing minimum L_p values for the N_{LP} enabled latency paths.
3	03 ₁₆ L2 Trim followed by: 1 octet for the proposed new value of $PCBds$ (dB) All other octet values are reserved by the ITU-T.

**Table 9-5/G.992.5 – Power management command transmitted
by the responding ATU**

Message length (octets)	Element name (Command)
2	80 ₁₆ Grant
3	81 ₁₆ Reject followed by: 1 octet for reason code
3	83 ₁₆ L2 Reject followed by: 1 octet for reason code
3	84 ₁₆ L2 Trim Grant followed by: 1 octet containing the exit symbol $PCBds$ value
3	85 ₁₆ L2 Trim Reject followed by: 1 octet for reason code
7 + 2 × N_{LP} + 4 × N_f	86 ₁₆ L2 Grant followed by: 2 × N_{LP} octets containing new L_p values for the N_{LP} enabled latency paths, 1 octet containing the actual $PCBds$ value 1 octet containing the exit symbol $PCBds$ value, 1 octet containing the exit symbol b_i/g_i table flag, 2 octets for the number of carriers N_f 4 × N_f octets describing subcarrier parameter field for each subcarrier All other octet values are reserved by the ITU-T.

In the L2 Request, L2 Grant, and L2 Trim Request, and L2 Trim Grant messages, power cutback values shall be expressed as an absolute power cutback in the range of 0 to 40 dB in steps of 1 dB. The cutback is defined in terms of $PCBds$. The minimum and maximum requested values are defined in absolute terms and not relative to the current $PCBds$ value. Values not inclusively within the range of the $PCBds$ determined during initialization to 40 dB shall not be encoded. It is intended that up to 40 dB of absolute power cutback can be performed for the L2 link state using the $PCBds$ control parameter and that the gain values can be used to additionally adjust the gain per carrier as required. The extra power cutback applied during the L2 state (i.e., $PCBds(L2) - PCBds(init)$) shall be applied as a flat cutback (i.e., each subcarrier is reduced by the same amount) relative to the L0

transmit PSD level (i.e., relative to the *REFPSDs*(init) transmit PSD level, adjusted by the *ceiled_log_tssi* values as determined and applied during transceiver training).

Reason codes associated with the power management commands are shown in Table 9-6.

Table 9-6/G.992.5 – Reason codes for power management commands

Reason	Octet value	Applicable to Reject	Applicable to L2 Reject	Applicable to L2 Trim Reject
Busy	01 ₁₆	X	X	
Invalid	02 ₁₆	X	X	X
State not desired	03 ₁₆	X		
Infeasible parameters	04 ₁₆		X	X

9.4.1.7.1 Simple request by ATU-R

See 9.4.1.7.1/G.992.3.

9.4.1.7.2 Simple request by ATU-C

See 9.4.1.7.2/G.992.3.

9.4.1.7.3 L2 Request by ATU-C

See 9.4.1.7.3/G.992.3.

9.4.1.7.4 L2 Trim Request by ATU-C

See 9.4.1.7.4/G.992.3.

9.4.1.8 Clear eoc messages

See 9.4.1.8/G.992.3.

9.4.1.9 Non-standard facility overhead commands

See 9.4.1.9/G.992.3.

9.4.1.10 Test parameter messages

The PMD test parameters read commands shall be used to access the value of certain PMD test parameters maintained by the far ATU in accordance with the description of the PMD function. The local parameter values shall be retrieved as described in this clause. The PMD test parameter read command may be initiated by either ATU as shown in Table 9-7. The responses shall be using the command shown in Table 9-8. The PMD test parameter read command shall consist of two octets. The first octet shall be the PMD test parameter command designator shown in Table 9-4. The second octet shall be one of the values shown in Table 9-7. The PMD test parameter read response command shall be multiple octets. The first octet shall be PMD test parameter read command designator shown in Table 9-4/G.992.3. The second shall correspond to received management counter read command. The remaining octets shall be as shown in Table 9-8. The octets shall be sent using the format described in 7.8.2.3/G.992.3 and using the protocol described in 7.8.2.4/G.992.3.

Table 9-7/G.992.5 – PMD test parameter read commands transmitted by the initiator

Message length (octets)	Element name (Command)
3	01 ₁₆ Single Read followed by: 1 octet describing the test parameter ID
2	03 ₁₆ Next Multiple Read
4	04 ₁₆ Multiple Read Block followed by: 2 octets describing the subcarrier index All other octet values are reserved by the ITU-T

Table 9-8/G.992.5 – PMD test parameter read command transmitted by the responder

Message length (octets)	Element name (Command)
Variable (see Note)	81 ₁₆ followed by: octets for the test parameter arranged for the single read format
12	82 ₁₆ followed by: octets for the test parameters arranged for the multiple read format
2	80 ₁₆ NACK All other octet values are reserved by the ITU-T.
NOTE – Variable length equals 2 plus length shown in Table 9-9.	

Table 9-9/G.992.5 – PMD test parameter ID values

Test parameter ID	Test parameter name	Length for single read	Length for multiple read
01 ₁₆	Channel Transfer Function $Hlog(f)$ per subcarrier	$2 + NSC \times 2$ octets	4 octets
02 ₁₆	Reserved by ITU-T		
03 ₁₆	Quiet Line Noise PSD $QLN(f)$ per subcarrier	$2 + NSC$ octets	3 octets
04 ₁₆	Signal-to-noise ratio $SNR(f)$ per subcarrier	$2 + NSC$ octets	3 octets
05 ₁₆	Reserved by ITU-T		
21 ₁₆	Line Attenuation $LATN$	2 octets	N/A
22 ₁₆	Signal Attenuation $SATN$	2 octets	N/A
23 ₁₆	Signal-to-Noise Margin $SNRM$	2 octets	N/A
24 ₁₆	Attainable Net Data Rate $ATTNDR$	4 octets	N/A
25 ₁₆	Near-end Actual Aggregate Transmit Power $ACTATP$	2 octets	N/A
26 ₁₆	Far-end Actual Aggregate Transmit Power $ACTATP$	2 octets	N/A

Upon receipt of one of the PMD test parameter read commands, the receiving ATU shall transmit the corresponding response message. If an unrecognized test parameter is requested, the response

shall be a PMD test parameter command for NACK. The function of the receiving or transmitting ATUs is not otherwise affected.

The PMD test parameters are all derived according to the procedures in the PMD function clause of this Recommendation. Following initialization, the PMD shall maintain training test parameters until the overhead command for update test parameters is received.

The parameters are transferred in the order and format defined in Table 9-9. During a test parameter read command for single read, all information for the test parameter is transferred. If the test parameter is an aggregate parameter, only one value is transferred. If the test parameter has a value per subcarrier, then all values are transferred from subcarrier index #0 to subcarrier index #NSC – 1 in a single message. The format of the octets is as described in the PMD clause. Values that are formatted as multiple octets shall be inserted in the response message in most significant to least significant octet order.

During a test parameter read command for multiple read or next, information for all test parameters associated with a particular subcarrier is transferred. Aggregate test parameters are not transferred with the PMD test parameter read command for multiple read or next. The subcarrier used for a PMD test parameter read command for multiple read shall be the subcarrier contained within the command. This subcarrier index shall be saved. Each subsequent PMD test parameter command for next shall increment and use the saved subcarrier index. If the subcarrier index reaches NSC, the response shall be a PMD test parameter command for NACK. The per subcarrier values are inserted into the message according to the numeric order of the octets designators show in Table 9-9. The format of the octets is as described in PMD clause of this Recommendation. Values that are formatted as multiple octets shall be inserted in the response message in most significant to least significant octet order.

In transferring the value of the channel transfer function $Hlog(f)$, the measurement time shall be inserted into the message, followed by the value m (see 8.12.3.1/G.992.3). The measurement time is included only once in a PMD test parameter response for single read. The measurement time is included in each response for multiple read or next multiple read.

In transferring the value of the quiet line noise $QLN(f)$, the measurement time shall be inserted into the message, followed by the n value (see 8.12.3.2/G.992.3). The measurement time is included only once in a PMD test parameter response for single read. The measurement time is included in each response for multiple read or next multiple read.

In transferring the value of the signal-to-noise ratio $SNR(f)$, the measurement time shall be inserted into the message, followed by the SNR value (see 8.12.3.3/G.992.3). The measurement time is included only once in a PMD test parameter response for single read. The measurement time is included in each response for multiple read or next multiple read.

The values for test parameters defined with fewer bits than shown in Table 9-9 shall be inserted into the message using the least significant bits of the two octets. Unused more significant bits shall be set to 0 for unsigned quantities and to the value of the sign bit for signed quantities.

9.4.1.10.1 Single read command

See 9.4.1.10.1/G.992.3.

9.4.4.10.2 Multiple read protocol with next

See 9.4.1.10.2/G.992.3.

9.5 Power management

See 9.5/G.992.3.

10 Dynamic behaviour

See 10/G.992.3.

Annex A

Specific requirements for an ADSL system operating in the frequency band above POTS

This annex defines those parameters of the ADSL system that have been left undefined in the body of this Recommendation because they are unique to an ADSL service that is frequency-division duplexed with POTS.

A.1 ATU-C functional characteristics (pertains to clause 8)

A.1.1 ATU-C control parameter settings

The ATU-C control parameter settings to be used in the parameterized parts of the main body and/or to be used in this annex are listed in Table A.1. Control parameters are defined in 8.5.

Table A.1/G.992.5 – ATU-C control parameter settings

Parameter	Default setting	Characteristics
<i>NSCds</i>	512	
<i>NOMPSDds</i>	–40 dBm/Hz	Settings may be changed relative to this value during G.994.1 phase; see 8.13.2.
<i>MAXNOMPSDds</i>	–40 dBm/Hz	Settings may be changed relative to this value during G.994.1 phase; see 8.13.2.
<i>MAXNOMATPds</i>	20.4 dBm	Settings may be changed relative to this value during G.994.1 phase; see 8.13.2.

A.1.2 ATU-C downstream transmit spectral mask for overlapped spectrum operation (supplements 8.10)

The passband is defined as the band from 25.875 to 2208 kHz and is the widest possible band used (i.e., for ADSL over POTS implemented with overlapped spectrum). Limits defined within the passband apply also to any narrower bands used.

Figure A.1 defines the limit spectral mask for the transmit signal. The low-frequency stopband is defined as frequencies below 25.875 kHz and includes the POTS band, the high-frequency stopband is defined as frequencies greater than 2208 kHz.

Figure A.1/G.992.5 – ATU-C transmitter PSD mask for overlapped spectrum operation

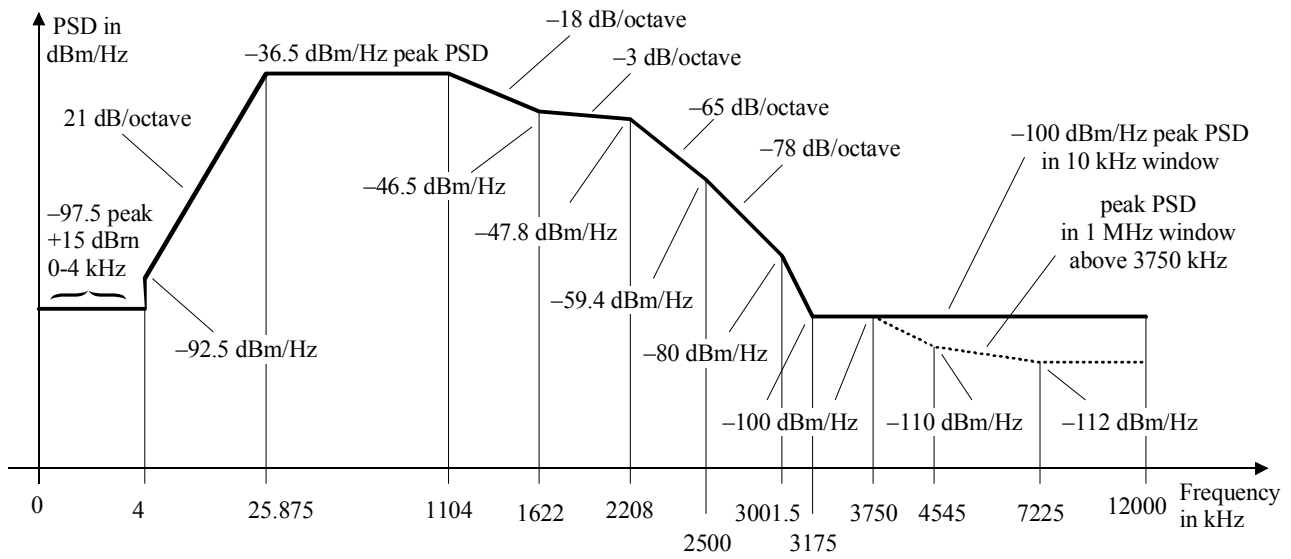

Frequency (kHz)	PSD level (dBm/Hz)	MBW
0	-97.5	100 Hz
4	-97.5	100 Hz
4	-92.5	100 Hz
10	interpolated	10 kHz
25.875	-36.5	10 kHz
1104	-36.5	10 kHz
1622	-46.5	10 kHz
2208	-47.8	10 kHz
2500	-59.4	10 kHz
3001.5	-80	10 kHz
3175	-100	10 kHz
12000	-100	10 kHz

Additionally, the PSD mask shall be satisfying the following requirements:

Frequency (kHz)	PSD level (dBm/Hz)	MBW
3750	-100	1 MHz
4545	-110	1 MHz
7225	-112	1 MHz
12000	-112	1 MHz

NOTE 1 – All PSD measurements are in 100 Ω; the POTS band total power measurement is in 600 Ω.

NOTE 2 – The breakpoint frequencies and PSD values are exact; the indicated slopes are approximate. The breakpoints in the tables shall be connected by linear straight lines on a dB/log(*f*) plot.

NOTE 3 – MBW specifies the measurement bandwidth. The MBW specified for a certain breakpoint with frequency *f_i* is applicable for all frequencies satisfying *f_i* < *f* ≤ *f_j*, where *f_j* is the frequency of the next specified breakpoint.

NOTE 4 – The power in a 1-MHz sliding window is measured in a 1-MHz bandwidth, starting at the measurement frequency, i.e., power in the [*f*, *f* + 1 MHz] window shall conform to the specification at frequency *f*.

NOTE 5 – The step in the PSD mask at 4 kHz is to protect V.90 performance. Originally, the PSD mask continued the 21-dB/octave slope below 4 kHz hitting a floor of -97.5 dBm/Hz at 3400 Hz. It was recognized that this might impact V.90 performance, and so the floor was extended to 4 kHz.

NOTE 6 – All PSD and power measurements shall be made at the U-C interface.

A.1.2.1 Passband PSD and response

There are three different PSD masks for the ATU-C transmit signal, depending on the type of signal sent. Across the whole passband, the transmit PSD level shall not exceed the maximum passband transmit PSD level, defined as:

- $NOMPSDds + 1$ dB, for initialization signals up to and including the Channel Discovery Phase;
- $REFPSDds + 1$ dB, during the remainder of initialization, starting with the Transceiver Training Phase;
- $MAXNOMPSDds - PCBds + 3.5$ dB, during showtime.

The group delay variation over the passband shall not exceed 50 μ s.

The maximum passband transmit PSD level allows for 1 dB of non-ideal transmit filter effects (e.g., passband ripple and transition band rolloff).

For spectrum management purposes, the ATU-C transmitter PSD template for overlapped spectrum operation is defined in Table A.2 (informative):

Table A.2/G.992.5 – ATU-C transmitter PSD template for overlapped spectrum operation

Frequency (kHz)	PSD level (dBm/Hz)
0	–101
4	–101
4	–96
25.875	–40
1104	–40
1622	–50
2208	–51.3
2500	–62.9
3001.5	–83.5
3175	–100
3750	–100
4545	–110
7225	–112
12000	–112

A.1.2.2 Aggregate transmit power

There are three different PSD masks for the ATU-C transmit signal, depending on the type of signal sent (see A.1.2.1). In all cases,

- the aggregate transmit power in the voiceband, measured at the U-C interface, and that is delivered to the Public Switched Telephone Network (PSTN) interface shall not exceed +15 dBm (see ITU-T Rec. G.996.1 [3] for method of measurement);
- the aggregate transmit power across the whole passband, shall not exceed ($MAXNOMATPds - PCBds$) by more than 0.5 dB, in order to accommodate implementational tolerances, and shall not exceed 20.9 dBm.

- the aggregate transmit power over the 0 to 12 MHz band, shall not exceed ($MAXNOMATPds - PCBds$) by more than 0.9 dB, in order to account for residual transmit power in the stopbands and implementational tolerances.

The power emitted by the ATU-C is limited by the requirements in this clause. Notwithstanding these requirements, it is assumed that the ADSL will comply with applicable national requirements on emission of electromagnetic energy.

For spectrum management purposes, the PSD template nominal passband aggregate transmit power is 20.4 dBm.

A.1.3 ATU-C transmitter PSD mask for non-overlapped spectrum operation (supplements 8.10)

Figure A.2 defines the limit spectral mask for the ATU-C transmitted signal, which results in reduced NEXT into the ADSL upstream band, relative to the mask in A.1.2. Adherence to this mask will in many cases result in improved upstream performance of the other ADSL systems in the same or adjacent binder group, with the improvement dependent upon the other interferers. This mask differs from the mask in A.1.2 only in the band from 4 kHz to 138 kHz.

The passband is defined as the band from 138 to 2208 kHz. Limits defined within the passband apply also to any narrower bands used.

The low-frequency stopband is defined as frequencies below 138 kHz and includes the POTS band, the high-frequency stopband is defined as frequencies greater than 2208 kHz.

Figure A.2/G.992.5 – ATU-C transmitter PSD mask for non-overlapped spectrum operation

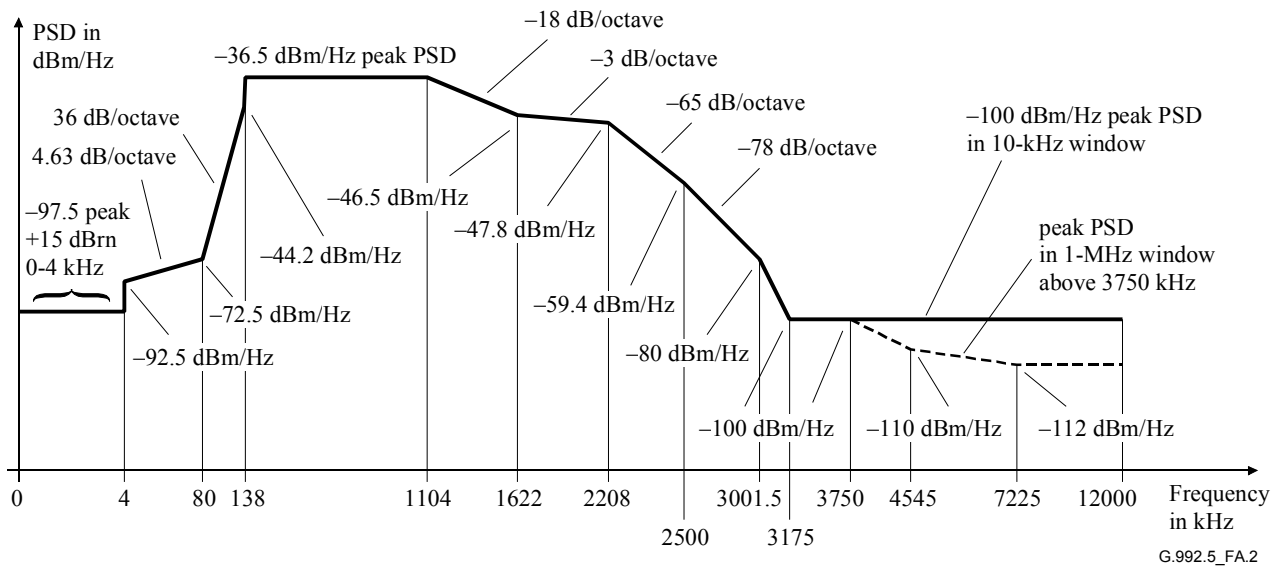

Frequency (kHz)	PSD level (dBm/Hz)	MBW
0	-97.5	100 Hz
4	-97.5	100 Hz
4	-92.5	100 Hz
10	interpolated	10 kHz
80	-72.5	10 kHz
138	-44.2	10 kHz
138	-36.5	10 kHz
1104	-36.5	10 kHz
1622	-46.5	10 kHz
2208	-47.8	10 kHz
2500	-59.4	10 kHz
3001.5	-80	10 kHz
3175	-100	10 kHz
12000	-100	10 kHz

Additionally, the PSD mask shall be satisfying the following requirements:

Frequency (kHz)	PSD level (dBm/Hz)	MBW
3750	-100	1 MHz
4545	-110	1 MHz
7225	-112	1 MHz
12000	-112	1 MHz

NOTE 1 – All PSD measurements are in 100 Ω; the POTS band total power measurement is in 600 Ω.

NOTE 2 – The breakpoint frequencies and PSD values are exact; the indicated slopes are approximate. The breakpoints in the tables shall be connected by linear straight lines on a dB/log(*f*) plot.

NOTE 3 – MBW specifies the measurement bandwidth. The MBW specified for a certain breakpoint with frequency *f_i* is applicable for all frequencies satisfying *f_i* < *f* ≤ *f_j*, where *f_j* is the frequency of the next specified breakpoint.

NOTE 4 – The power in a 1-MHz sliding window is measured in a 1-MHz bandwidth, starting at the measurement frequency, i.e., power in the [*f*, *f* + 1 MHz] window shall conform to the specification at frequency *f*.

NOTE 5 – The step in the PSD mask at 4 kHz is to protect V.90 performance. Originally, the PSD mask continued the 21-dB/octave slope below 4 kHz hitting a floor of -97.5 dBm/Hz at 3400 Hz. It was recognized that this might impact V.90 performance, and so the floor was extended to 4 kHz.

NOTE 6 – All PSD and power measurements shall be made at the U-C interface.

A.1.3.1 Passband PSD and response

See A.1.2.1. For spectrum management purposes, the PSD template for non-overlapped spectrum operation is defined in Table A.3 (informative):

Table A.3/G.992.5 – ATU-C transmitter PSD template for non-overlapped spectrum operation

Frequency (kHz)	PSD level (dBm/Hz)
0	– 101
4	– 101
4	– 96
80	– 76
138	– 47.7
138	– 40
1104	– 40
1622	– 50
2208	– 51.3
2500	– 62.9
3001.5	– 83.5
3175	– 100
3750	– 100
4545	– 110
7225	– 112
12000	– 112

A.1.3.2 Aggregate transmit power

See A.1.2.2. In addition, for non-overlapped spectrum operation, the aggregate transmit power across the whole passband shall not exceed 20.4 dBm.

For spectrum management purposes, the PSD template nominal passband aggregate transmit power is 19.9 dBm.

A.2 ATU-R functional characteristics (pertains to clause 8)

A.2.1 ATU-R control parameter settings

The ATU-R control parameter settings to be used in the parameterized parts of the main body and/or to be used in this annex are listed in Table A.4. Control parameters are defined in 8.5.

Table A.4/G.992.5 – ATU-R control parameter settings

Parameter	Default setting	Characteristics
<i>NSCus</i>	32	
<i>NOMPSDus</i>	–38 dBm/Hz	Settings may be changed relative to this value during G.994.1 phase; see 8.13.2.
<i>MAXNOMPSDus</i>	–38 dBm/Hz	Settings may be changed relative to this value during G.994.1 phase; see 8.13.2.
<i>MAXNOMATPus</i>	12.5 dBm	Settings may be changed relative to this value during G.994.1 phase; see 8.13.2.

A.2.2 ATU-R upstream transmit spectral mask (supplements 8.10)

The passband is defined as the band from 25.875 to 138 kHz and is the widest possible band used. Limits defined within the passband apply also to any narrower bands used.

Figure A.3 defines the spectral mask for the transmit signal. The low-frequency stopband is defined as frequencies below 25.875 kHz and includes the POTS band (see also Figure A.1), the high-frequency stopband is defined as frequencies greater than 138 kHz.

Figure A.3/G.992.5 – ATU-R transmitter PSD mask

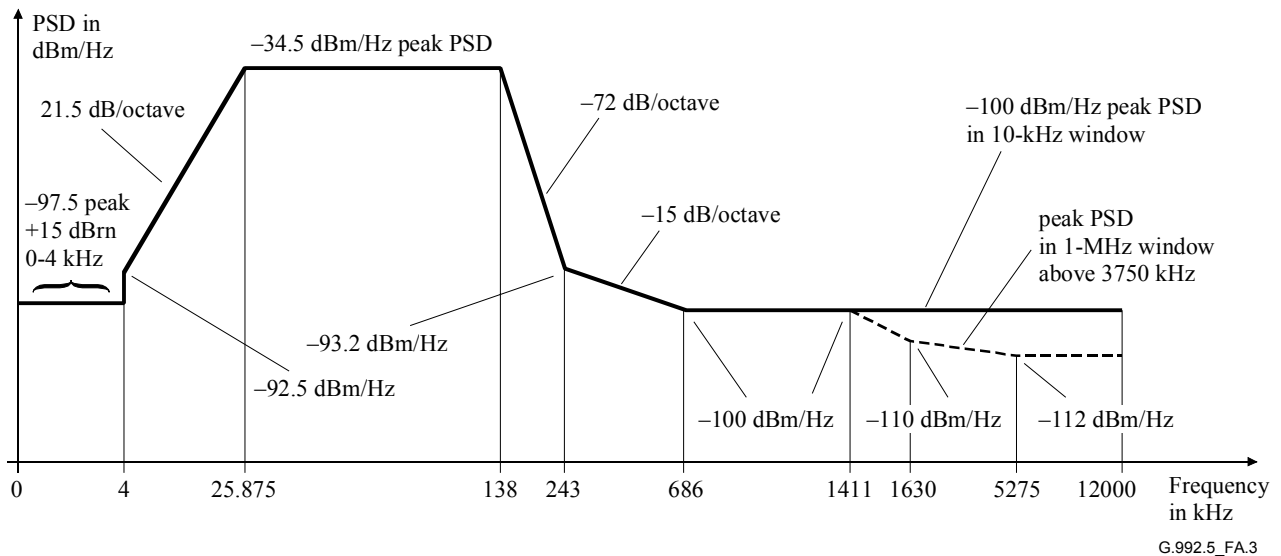

Frequency (kHz)	PSD level (dBm/Hz)	MBW
0	-97.5	100 Hz
4	-97.5	100 Hz
4	-92.5	100 Hz
10	interpolated	10 kHz
25.875	-34.5	10 kHz
138	-34.5	10 kHz
243	-93.2	10 kHz
686	-100	10 kHz
5275	-100	10 kHz
12000	-100	10 kHz

Additionally the PSD mask shall be satisfying following requirements:

Frequency (kHz)	PSD level (dBm/Hz)	MBW
1411	-100	1 MHz
1630	-110	1 MHz
5275	-112	1 MHz
12000	-112	1 MHz

NOTE 1 – All PSD measurements are in 100 Ω; the POTS band total power measurement is in 600 Ω.

NOTE 2 – The breakpoint frequencies and PSD values are exact; the indicated slopes are approximate. The breakpoints in the tables shall be connected by linear straight lines on a dB/log(*f*) plot.

NOTE 3 – MBW specifies the measurement bandwidth. The MBW specified for a certain breakpoint with frequency *f_i* is applicable for all frequencies satisfying *f_i* < *f* ≤ *f_j*, where *f_j* is the frequency of the next specified breakpoint.

NOTE 4 – The power in a 1-MHz sliding window is measured in a 1-MHz bandwidth, starting at the measurement frequency, i.e., power in the [*f*, *f* + 1 MHz] window shall conform to the specification at frequency *f*.

NOTE 5 – The step in the PSD mask at 4 kHz is to protect V.90 performance. Originally, the PSD mask continued the 21-dB/octave slope below 4 kHz hitting a floor of -97.5 dBm/Hz at 3400 Hz. It was recognized that this might impact V.90 performance, and so the floor was extended to 4 kHz.

NOTE 6 – All PSD and power measurements shall be made at the U-C interface.

A.2.2.1 Passband PSD and response

There are three different PSD masks for the ATU-R transmit signal, depending on the type of signal sent. Across the whole passband, the transmit PSD level shall not exceed the maximum passband PSD level, defined as:

- $NOMPSD_{us} + 1$ dB, for initialization signals up to and including the Channel Discovery Phase;
- $REFPSD_{us} + 1$ dB, during the remainder of initialization, starting with the Transceiver Training Phase;
- $MAXNOMPSD_{us} - PCBus + 3.5$ dB, during showtime.

The group delay variation over the passband shall not exceed 50 μ s.

The maximum transmit PSD level allows for a 1 dB of non-ideal transmit filter effects (e.g. passband ripple and transition band rolloff).

For spectrum management purposes, the PSD template is defined in Table A.5 (informative):

Table A.5/G.992.5 – ATU-R transmitter PSD template

Frequency (kHz)	PSD level (dBm/Hz)
0	–101
4	–101
4	–96
25.875	–38
138	–38
229.6	–92.9
686	–100
1411	–100
1630	–110
5275	–112
12000	–112

A.2.2.2 Aggregate transmit power

There are three different PSD masks for the ATU-R transmit signal, depending on the type of signal sent (see A.2.2.1). In all cases:

- the aggregate transmit power in the voiceband, measured at the U-R interface, and that is delivered to the Plain Old Telephone Service (POTS) interface shall not exceed +15 dB_{rn} (see ITU-T Rec. G.996.1 [3] for method of measurement);
- the aggregate transmit power across the whole passband, shall not exceed ($MAXNOMATP_{us} - PCBus$) by more than 0.5 dB, in order to accommodate implementational tolerances, and shall not exceed 13.0 dBm.
- the aggregate transmit power over the 0 to 12 MHz band, shall not exceed ($MAXNOMATP_{us} - PCBus$) by more than 0.8 dB, in order to account for residual transmit power in the stopbands and implementational tolerances.

The power emitted by the ATU-R is limited by the requirements in this clause. Notwithstanding these requirements, it is assumed that the ADSL will comply with applicable national requirements on emission of electromagnetic energy.

For spectrum management purposes, the PSD template nominal passband aggregate transmit power is 12.5 dBm.

A.3 Initialization

For this annex, no additional requirements apply (relative to the main body of this Recommendation).

A.4 Electrical characteristics

See A.4/G.992.3.

The G.992.3 requirements applying over a frequency band up to 1104 kHz shall be met over a frequency band up to 2208 kHz.

Annex B

Specific requirements for an ADSL system operating in the frequency band above ISDN as defined in ITU-T Rec. G.961 Appendices I and II

This annex defines those parameters of the ADSL system that have been left undefined in the body of this Recommendation because they are unique to an ADSL service that is frequency-division duplexed with ISDN-BA on the same digital subscriber line. The scope is to establish viable ways enabling the simultaneous deployment of ADSL and 160 kbit/s (2B + D) Basic Rate Access with the constraint to use existing transmission technologies as those specified in Appendices I and II/G.961 [1].

B.1 ATU-C functional characteristics (pertains to clause 8)

B.1.1 ATU-C control parameter settings

The ATU-C control parameter settings to be used in the parameterized parts of the main body and/or to be used in this annex are listed in Table B.1. Control parameters are defined in 8.5.

Table B.1/G.992.5 – ATU-C control parameter settings

Parameter	Default setting	Characteristics
<i>NSCds</i>	512	
<i>NOMPSDds</i>	−40 dBm/Hz	Settings may be changed relative to this value during G.994.1 phase; see 8.13.2.
<i>MAXNOMPSDds</i>	−40 dBm/Hz	Settings may be changed relative to this value during G.994.1 phase; see 8.13.2.
<i>MAXNOMATPds</i>	19.9 dBm	Settings may be changed relative to this value during G.994.1 phase; see 8.13.2.

B.1.2 ATU-C downstream transmit spectral mask for overlapped spectrum operation (supplements 8.10)

The passband is defined as the band from 120 kHz (see Figure B.1) to 2208 kHz and is the widest possible band used (i.e., for ADSL over ISDN implemented with overlapped spectrum). Limits defined within the passband apply also to any narrower bands used.

Figure B.1 defines the limit spectral mask for the transmit signal. The low-frequency stopband is the ISDN band and is defined as frequencies below 120 kHz (see Figure B.1); the high-frequency stopband is defined as frequencies greater than 2208 kHz.

Figure B.1/G.992.5 – ATU-C transmitter PSD mask for overlapped spectrum operation

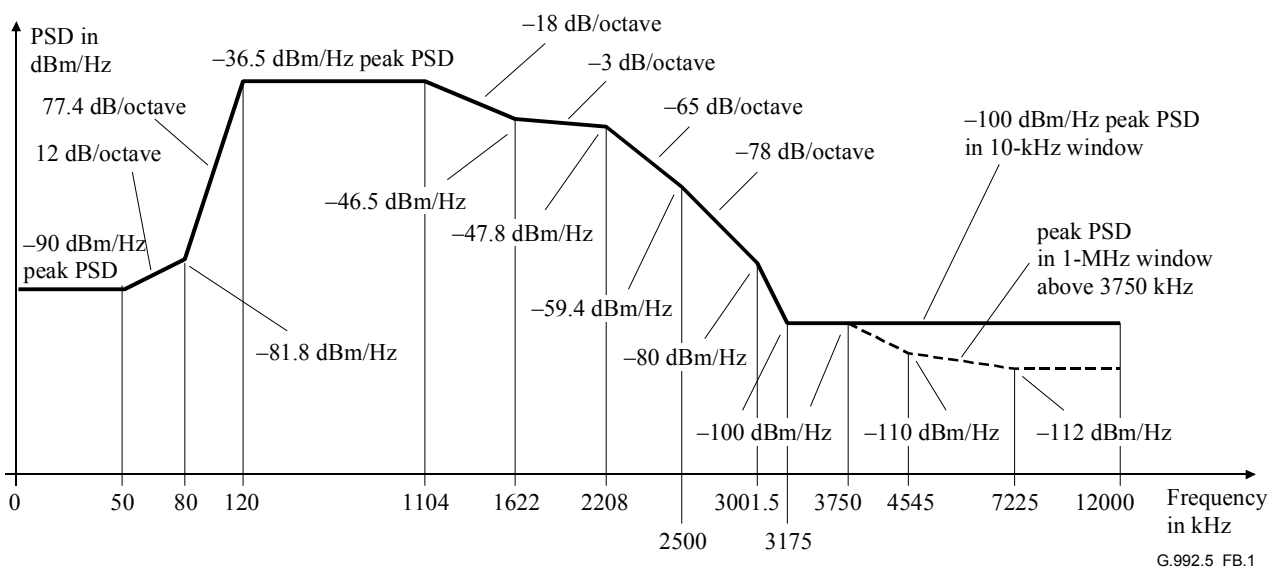

Frequency (kHz)	PSD level (dBm/Hz)	MBW
0	-90	10 kHz
50	-90	10 kHz
80	-81.8	10 kHz
120	-36.5	10 kHz
1104	-36.5	10 kHz
1622	-46.5	10 kHz
2208	-47.8	10 kHz
2500	-59.4	10 kHz
3001.5	-80	10 kHz
3175	-100	10 kHz
12000	-100	10 kHz

Additionally, the PSD mask shall be satisfying following requirements:

Frequency (kHz)	PSD level (dBm/Hz)	MBW
3750	-100	1 MHz
4545	-110	1 MHz
7225	-112	1 MHz
12000	-112	1 MHz

NOTE 1 – All PSD measurements shall measure the spectral power into a resistive load having a value of 100 Ω.

NOTE 2 – The breakpoint frequencies and PSD values are exact; the indicated slopes are approximate. The breakpoints in the tables shall be connected by linear straight lines on a dB/log(*f*) plot.

NOTE 3 – MBW specifies the measurement bandwidth. The MBW specified for a certain breakpoint with frequency *f_i* is applicable for all frequencies satisfying *f_i* < *f* ≤ *f_j*, where *f_j* is the frequency of the next specified breakpoint.

NOTE 4 – The power in a 1-MHz sliding window is measured in a 1-MHz bandwidth, starting at the measurement frequency, i.e., power in the [*f*, *f* + 1 MHz] window shall conform to the specification at frequency *f*.

NOTE 5 – All PSD and power measurements shall be made at the U-C interface.

The ISDN port of the ISDN splitter shall be terminated with the appropriate 2B1Q or 4B3T design impedance for ISDN-BA as defined in ETSI TS 102 080 [6].

It is intended that the degradation impact on the ISDN-BA line system performance be no more than 4.5 dB and 4 dB, for 2B1Q and 4B3T line codes respectively, at the insertion loss reference frequency.

B.1.2.1 Passband PSD and response

There are three different PSD masks for the ATU-C transmit signal, depending on the type of signal sent. Across the whole passband, the transmit PSD level shall not exceed the maximum passband transmit PSD level, defined as:

- $NOMPSDds + 1$ dB, for initialization signals up to and including the Channel Discovery Phase;
- $REFPSDds + 1$ dB, during the remainder of initialization, starting with the Transceiver Training Phase;
- $MAXNOMPSDds - PCBds + 3.5$ dB, during showtime.

The group delay variation over the passband shall not exceed 50 μ s.

The maximum transmit PSD allows for a 1 dB of non-ideal transmit filter effects (e.g., passband ripple and transition band rolloff).

For spectrum management purposes, the PSD template is defined in Table B.2 (informative):

Table B.2/G.992.5 – ATU-C transmitter PSD template for overlapped spectrum operation

Frequency (kHz)	PSD level (dBm/Hz)
0	–90
50	–90
80	–85.3
120	–40
1104	–40
1622	–50
2208	–51.3
2500	–62.9
3001.5	–83.5
3175	–100
3750	–100
4545	–110
7225	–112
12000	–112

B.1.2.2 Aggregate transmit power

There are three different PSD masks for the ATU-C transmit signal, depending on the type of signal sent (see B.1.2.1). In all cases:

- the aggregate transmit power across the whole passband shall not exceed ($MAXNOMATPds - PCBds$) by more than 0.5 dB, in order to accommodate implementational tolerances, and shall not exceed 20.4 dBm;
- the aggregate transmit power over the 0 to 11.040 MHz band, shall not exceed ($MAXNOMATPds - PCBds$) by more than 0.9 dB, in order to account for residual transmit power in the stopbands and implementational tolerances.

The power emitted by the ATU-C is limited by the requirements in this clause. Notwithstanding these requirements, it is assumed that the ADSL will comply with applicable national requirements on emission of electromagnetic energy.

For spectrum management purposes, the PSD template nominal passband aggregate transmit power is 19.9 dBm.

B.1.3 ATU-C transmitter PSD mask for non-overlapped spectrum operation (supplements 8.10)

Figure B.2 defines the limit spectral mask for the ATU-C transmitted signal, which results in reduced NEXT into the ADSL upstream band, relative to the mask in B.1.2. Adherence to this mask will in many cases result in improved upstream performance of the other ADSL systems in the same or adjacent binder group, with the improvement dependent upon the other interferers. This mask differs from the mask in B.1.2 only in the band from 50 kHz to 254 kHz.

The passband is defined as the band from 254 to 2208 kHz. Limits defined within the passband apply also to any narrower bands used.

The low-frequency stopband is defined as frequencies below 254 kHz and includes the ISDN band, the high-frequency stopband is defined as frequencies greater than 2208 kHz.

Figure B.2/G.992.5 – ATU-C transmitter PSD mask for non-overlapped spectrum operation

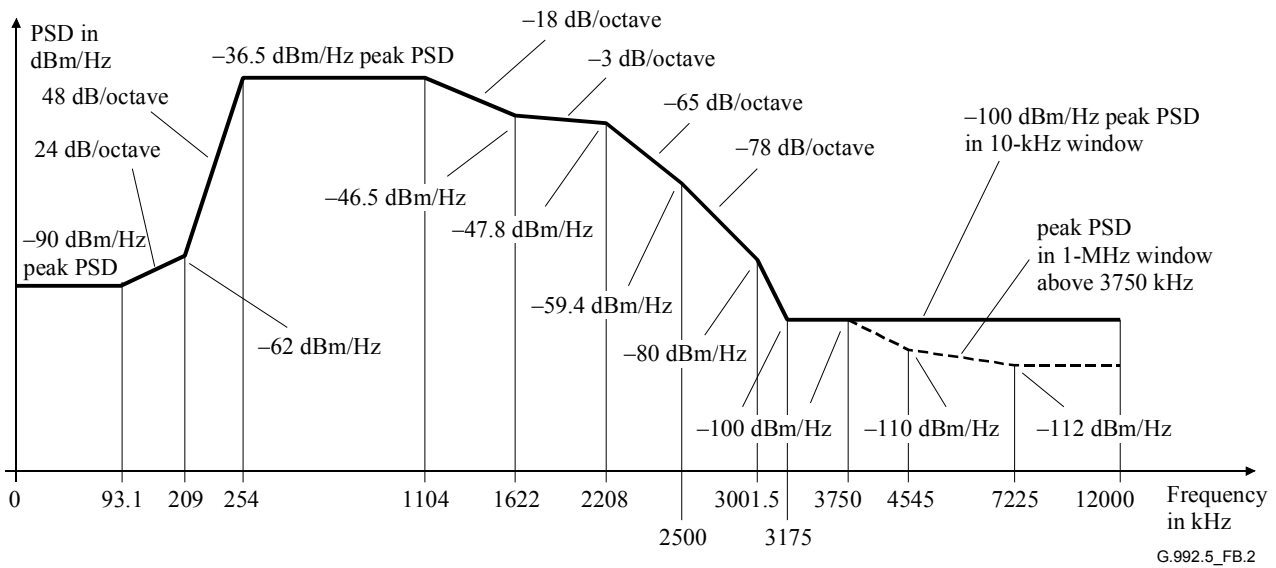

Frequency (kHz)	PSD level (dBm/Hz)	MBW
0	-90	10 kHz
93.1	-90	10 kHz
209	-62	10 kHz
254	-48.5	10 kHz
254	-36.5	10 kHz
1104	-36.5	10 kHz
1622	-46.5	10 kHz
2208	-47.8	10 kHz
2500	-59.4	10 kHz
3001.5	-80	10 kHz
3175	-100	10 kHz
12000	-100	10 kHz

Additionally, the PSD mask shall be satisfying following requirements:

Frequency (kHz)	PSD level (dBm/Hz)	MBW
3750	-100	1 MHz
4545	-110	1 MHz
7225	-112	1 MHz
12000	-112	1 MHz

NOTE 1 – All PSD measurements shall measure the spectral power into a resistive load having a value of 100 Ω.

NOTE 2 – The breakpoint frequencies and PSD values are exact; the indicated slopes are approximate. The breakpoints in the tables shall be connected by linear straight lines on a dB/log(*f*) plot.

NOTE 3 – MBW specifies the measurement bandwidth. The MBW specified for a certain breakpoint with frequency *f_i* is applicable for all frequencies satisfying *f_i* < *f* ≤ *f_j*, where *f_j* is the frequency of the next specified breakpoint.

NOTE 4 – The power in a 1-MHz sliding window is measured in a 1-MHz bandwidth, starting at the measurement frequency, i.e., power in the [*f*, *f* + 1 MHz] window shall conform to the specification at frequency *f*.

NOTE 5 – All PSD and power measurements shall be made at the U-C interface.

The ISDN port of the ISDN splitter shall be terminated with the appropriate 2B1Q or 4B3T design impedance for ISDN-BA as defined in ETSI TS 102 080 [6].

It is intended that the degradation impact on the ISDN-BA line system performance be no more than 4.5 dB and 4 dB, for 2B1Q and 4B3T line codes respectively, at the insertion loss reference frequency.

B.1.3.1 Passband PSD and response

See § B.1.2.1. For spectrum management purposes, the PSD template is defined in Table B.3 (informative):

Table B.3/G.992.5 – ATU-C transmitter PSD template for non-overlapped spectrum operation

Frequency (kHz)	PSD level (dBm/Hz)
0	–90
93.1	–90
209	–65.5
254	–52
254	–40
1104	–40
1622	–50
2208	–51.3
2500	–62.9
3001.5	–83.5
3175	–100
3750	–100
4545	–110
7225	–112
12000	–112

B.1.3.2 Aggregate transmit power

See B.1.2.2. In addition, for non-overlapped spectrum operation, the aggregate transmit power across the whole passband shall not exceed 19.8 dBm.

For spectrum management purposes, the PSD template nominal passband aggregate transmit power is 19.3 dBm.

B.2 ATU-R functional characteristics (pertains to clause 8)

B.2.1 ATU-R control parameter settings

The ATU-R control parameter settings to be used in the parameterized parts of the main body and/or to be used in this annex are listed in Table B.4. Control parameters are defined in 8.5.

Table B.4/G.992.5 – ATU-R control parameter settings

Parameter	Default setting	Characteristics
<i>NSC_{us}</i>	64	
<i>NOMPSD_{us}</i>	–38 dBm/Hz	Setting may be changed relative to this value during G.994.1 phase; see 8.13.2.
<i>MAXNOMPSD_{us}</i>	–38 dBm/Hz	Setting may be changed relative to this value during G.994.1 phase; see 8.13.2.
<i>MAXNOMATP_{us}</i>	13.3 dBm	Setting may be changed relative to this value during G.994.1 phase; see 8.13.2.
Tones 1 to 32	Enabled/Disabled	Signifies that the transmission of upstream tones 1 to 32 (or a subset thereof) is enabled/disabled. Negotiated in the G.994.1 phase (see B.3).

B.2.2 ATU-R upstream transmit spectral mask (supplements 8.10)

The passband is defined as the band from 120 kHz (see Figure B.1) to 276 kHz and is the widest possible band used. Limits defined within the passband apply also to any narrower bands used.

Figure B.3 defines the spectral mask for the transmit signal. The low-frequency stopband is the ISDN band and is defined as frequencies below 120 kHz (see Figure B.1). The high-frequency stopband is defined as frequencies greater than 276 kHz.

Figure B.3/G.992.5 – ATU-R transmitter PSD mask

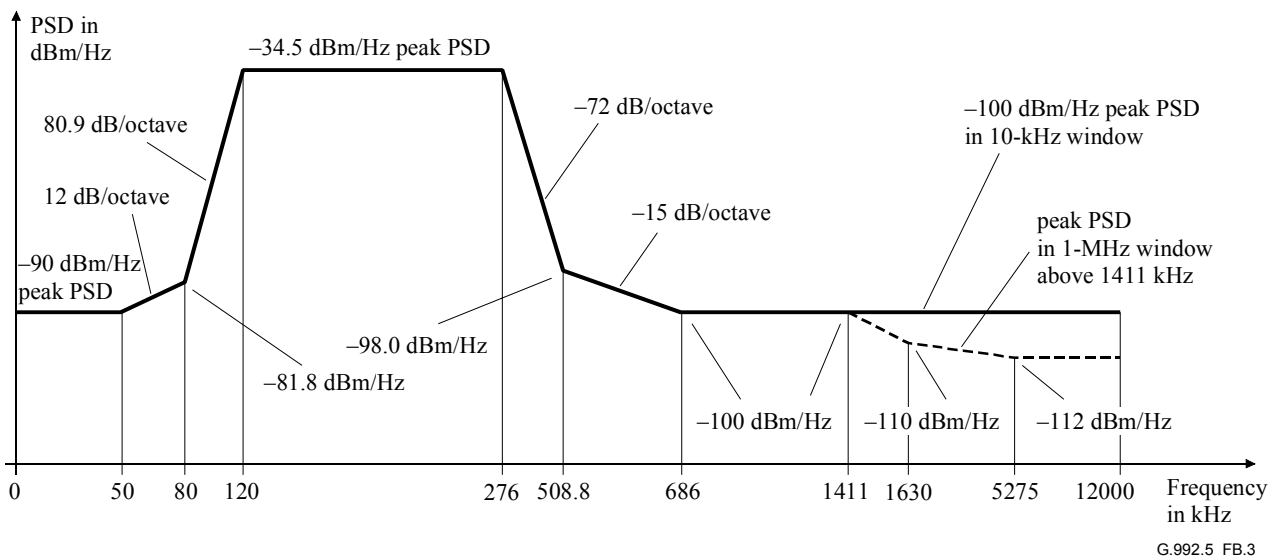

Frequency (kHz)	PSD level (dBm/Hz)	MBW
0	-90	10 kHz
50	-90	10 kHz
80	-81.8	10 kHz
120	-34.5	10 kHz
276	-34.5	10 kHz
508.8	-98.0	10 kHz
686	-100	10 kHz
5275	-100	10 kHz
12000	-100	10 kHz

Additionally the PSD mask shall be satisfying following requirements:

Frequency (kHz)	PSD level (dBm/Hz)	MBW
1411	-100	1 MHz
1630	-110	1 MHz
5275	-112	1 MHz
12000	-112	1 MHz

NOTE 1 – All PSD measurements shall measure the spectral power into a resistive load having a value of 100 Ω.

NOTE 2 – The breakpoint frequencies and PSD values are exact; the indicated slopes are approximate. The breakpoints in the tables shall be connected by linear straight lines on a dB/log(*f*) plot.

NOTE 3 – MBW specifies the measurement bandwidth. The MBW specified for a certain breakpoint with frequency *f_i* is applicable for all frequencies satisfying *f_i* < *f* ≤ *f_j*, where *f_j* is the frequency of the next specified breakpoint.

NOTE 4 – The power in a 1-MHz sliding window is measured in a 1-MHz bandwidth, starting at the measurement frequency, i.e., power in the [*f*, *f* + 1 MHz] window shall conform to the specification at frequency *f*.

NOTE 5 – All PSD and power measurements shall be made at the U-C interface.

NOTE 6 – The upstream PSD mask is intended for use with ISDN 2B1Q and ISDN 4B3T. However, some deployments have reported field issues with ISDN 4B3T NT activation when operating with ADSL overlay. ISDN passband versus ADSL passband tradeoff and ISDN splitter characteristics need further study. A result thereof could be a limitation of the ADSL transmit power below 138 kHz when operating over ISDN 4B3T. Such transmit power limitation can be achieved through frequency domain shaping or masking of the tones below tone index 33 (if the ATU-R transmitter supports tones 1 to 32) or through time-domain filtering with filter rolloff from 138 kHz (if the ATU-R transmitter does not support tones 1 to 32).

The ISDN port of the ISDN splitter shall be terminated with the appropriate 2B1Q or 4B3T design impedance for ISDN-BA as defined in ETSI TS 102 080 [6].

It is intended that the degradation impact on the ISDN-BA line system performance be no more than 4.5 dB and 4 dB, for 2B1Q and 4B3T line codes respectively, at the insertion loss reference frequency.

B.2.2.1 Passband PSD and response

There are three different PSD masks for the ATU-R transmit signal, depending on the type of signal sent. Across the whole passband, the transmit PSD level shall not exceed the maximum passband transmit PSD level, defined as:

- $NOMPSD_{us} + 1$ dB, for initialization signals up to and including the Channel Discovery Phase;
- $REFPSD_{us} + 1$ dB, during the remainder of initialization, starting with the Transceiver Training Phase;
- $MAXNOMPSD_{us} - PCBus + 3.5$ dB, during showtime.

The group delay variation over the passband shall not exceed 50 μ s.

The maximum transmit PSD allows for a 1 dB of non-ideal transmit filter effects (e.g., passband ripple and transition band rolloff).

For spectrum management purposes, the PSD template is defined in Table B.5 (informative):

Table B.5/G.992.5 – ATU-R transmitter PSD template

Frequency (kHz)	PSD level (dBm/Hz)
0	–90
50	–90
80	–85.3
120	–38
276	–38
491	–97.8
686	–100
1411	–100
1630	–110
5275	–112
12000	–112

B.2.2.2 Aggregate transmit power

There are three different PSD masks for the ATU-R transmit signal, depending on the type of signal sent (see B.2.2.1). In all cases:

- the aggregate transmit power across the whole passband, shall not exceed $(MAXNOMATP_{us} - PCBus)$ by more than 0.5 dB, in order to accommodate implementational tolerances, and shall not exceed 13.8 dBm;
- the aggregate transmit power over the 0 to 11.040 MHz band shall not exceed $(MAXNOMATP_{us} - PCBus)$ by more than 0.8 dB, in order to account for residual transmit power in the stopbands and implementational tolerances.

The power emitted by the ATU-R is limited by the requirements in this clause. Notwithstanding these requirements, it is assumed that the ADSL will comply with applicable national requirements on emission of electromagnetic energy.

For spectrum management purposes, the PSD template nominal passband aggregate transmit power is 13.3 dBm.

B.3 Initialization

See B.3/G.992.3.

B.4 Electrical characteristics

See B.4/G.992.3.

The G.992.3 requirements applying over a frequency band up to 1104 kHz shall be met over a frequency band up to 2208 kHz.

Annex C

Specific requirements for an ADSL system operating in the same cable as ISDN as defined in ITU-T Rec. G.961 Appendix III

For further study.

Annex D

ATU-C and ATU-R state diagrams

See Annex D/G.992.3.

Annex E

POTS and ISDN-BA splitters

See Annex E/G.992.3.

For operation according to Annexes A, B and I, the G.992.3 requirements applying over a frequency band up to 1104 kHz shall be met over a frequency band up to 2208 kHz.

Annex F

ATU-x performance requirements for Region A (North America)

F.1 Performance requirements for operation of ADSL over POTS (Annex A)

For further study.

F.2 Performance requirements for operation of All Digital Mode ADSL (Annex I)

For further study.

F.3 Performance requirements for operation of ADSL over POTS, with extended upstream bandwidth (Annex L)

For further study.

Annex G

ATU-x performance requirements for Region B (Europe)

G.1 Performance requirements for operation of ADSL over POTS (Annex A)

For further study.

G.2 Performance requirements for operation of ADSL over ISDN (Annex B)

For further study.

G.3 Performance requirements for operation of All Digital Mode ADSL (Annex I)

For further study.

G.4 Performance requirements for operation of All Digital Mode ADSL (Annex J)

For further study.

G.5 Performance requirements for operation of ADSL over POTS, with extended upstream bandwidth (Annex L)

For further study.

Annex H

Specific requirements for a synchronized symmetrical DSL (SSDSL) system operating in the same cable binder as ISDN as defined in ITU-T Rec. G.961 Appendix III

For further study.

Annex I

All Digital Mode ADSL with improved spectral compatibility with ADSL over POTS

This annex defines those parameters of the ADSL system that have been left undefined in the body of this Recommendation because they are unique to an all digital ADSL service with improved spectral compatibility with ADSL over POTS.

I.1 ATU-C functional characteristics (pertains to clause 8)

I.1.1 ATU-C control parameter settings

The ATU-C control parameter settings to be used in the parameterized parts of the main body and/or to be used in this annex are listed in Table I.1. Control parameters are defined in 8.5.

Table I.1/G.992.5 – ATU-C control parameter settings

Parameter	Default setting	Characteristics
<i>NSCds</i>	512	
<i>NOMPSDds</i>	–40 dBm/Hz	Settings may be changed relative to this value during G.994.1 phase; see 8.13.2.
<i>MAXNOMPSDds</i>	–40 dBm/Hz	Settings may be changed relative to this value during G.994.1 phase; see 8.13.2.
<i>MAXNOMATPds</i>	20.4 dBm	Settings may be changed relative to this value during G.994.1 phase; see 8.13.2.

I.1.2 ATU-C downstream transmit spectral mask for overlapped spectrum operation (supplements 8.10)

The passband is defined as the band from 3 to 2208 kHz and is the widest possible band used (i.e., implemented with overlapped spectrum). Limits defined within the passband apply also to any narrower bands used.

Figure I.1 defines the limit spectral mask for the transmit signal. The low-frequency stopband is defined as frequencies below 3 kHz, the high-frequency stopband is defined as frequencies greater than 2208 kHz.

Figure I.1/G.992.5 – ATU-C transmitter PSD mask for overlapped spectrum operation

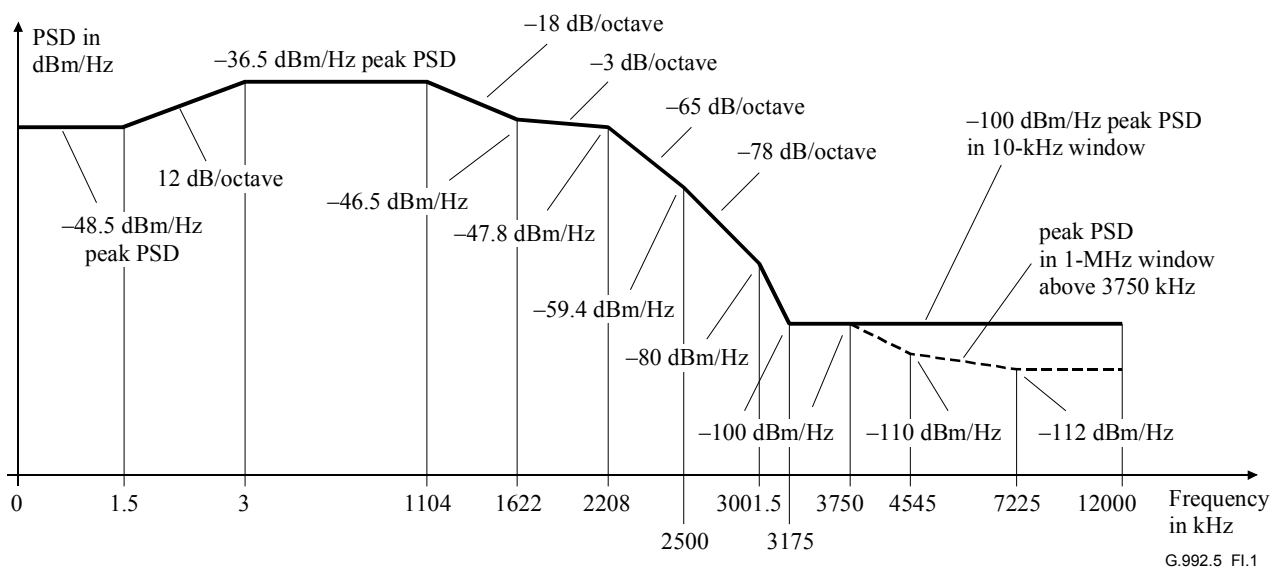

Frequency (kHz)	PSD level (dBm/Hz)	MBW
0	-48.5	100 Hz
1.5	-48.5	100 Hz
3	-36.5	100 Hz
10	-36.5	10 kHz
25.875	-36.5	10 kHz
1104	-36.5	10 kHz
1622	-46.5	10 kHz
2208	-47.8	10 kHz
2500	-59.4	10 kHz
3001.5	-80	10 kHz
3175	-100	10 kHz
12000	-100	10 kHz

Additionally, the PSD mask shall be satisfying following requirements:

Frequency (kHz)	PSD level (dBm/Hz)	MBW
3750	-100	1 MHz
4545	-110	1 MHz
7225	-112	1 MHz
12000	-112	1 MHz

NOTE 1 – All PSD measurements are in 100 Ω.

NOTE 2 – The breakpoint frequencies and PSD values are exact; the indicated slopes are approximate. The breakpoints in the tables shall be connected by linear straight lines on a dB/log(*f*) plot.

NOTE 3 – MBW specifies the measurement bandwidth. The MBW specified for a certain breakpoint with frequency *f_i* is applicable for all frequencies satisfying *f_i* < *f* ≤ *f_j*, where *f_j* is the frequency of the next specified breakpoint.

NOTE 4 – The power in a 1-MHz sliding window is measured in a 1-MHz bandwidth, starting at the measurement frequency, i.e., power in the [*f*, *f* + 1 MHz] window shall conform to the specification at frequency *f*.

NOTE 5 – All PSD and power measurements shall be made at the U-C interface.

NOTE – When deployed in the same cable as ADSL-over-POTS (Annex A/G.992.1, Annexes A and B/G.992.2, Annex A/G.992.3 and Annex A/G.992.4), there may be a spectral compatibility issue between the two systems due to the overlap of the All-Digital Loop downstream channel with the ADSL-over-POTS upstream channel at frequencies below 138 kHz. Detailed study of spectrum compatibility is referred to regional bodies. Deployment restrictions for systems using the downstream PSD masks defined in this annex may be imposed (e.g., by the regional regulatory authority).

I.1.2.1 Passband PSD and response

There are three different PSD masks for the ATU-C transmit signal, depending on the type of signal sent. Across the whole passband, the transmit PSD level shall not exceed the maximum passband transmit PSD level, defined as:

- $NOMPSDds + 1$ dB, for initialization signals up to and including the Channel Discovery Phase;
- $REFPSDds + 1$ dB, during the remainder of initialization, starting with the Transceiver Training Phase;
- $MAXNOMPSDds - PCBds + 3.5$ dB, during showtime.

The group delay variation over the passband shall not exceed 50 μ s.

The maximum passband transmit PSD level allows for 1 dB of non-ideal transmit filter effects (e.g. passband ripple and transition band rolloff).

For spectrum management purposes, the ATU-C transmitter PSD template for overlapped spectrum operation is defined in Table I.2 (informative):

Table I.2/G.992.5 – ATU-C transmitter PSD template for overlapped spectrum operation

Frequency (kHz)	PSD level (dBm/Hz)
0	-52
1.5	-52
3	-40
1104	-40
1622	-50
2208	-51.3
2500	-62.9
3001.5	-83.5
3175	-100
3750	-100
4545	-110
7225	-112
12000	-112

I.1.2.2 Aggregate transmit power

There are three different PSD masks for the ATU-C transmit signal, depending on the type of signal sent (see I.1.2.1). In all cases:

- the aggregate transmit power across the whole passband shall not exceed ($MAXNOMATPds - PCBds$) by more than 0.5 dB, in order to accommodate implementational tolerances, and shall not exceed 20.9 dBm.
- the aggregate transmit power over the 0 to 12 MHz band shall not exceed ($MAXNOMATPds - PCBds$) by more than 0.9 dB, in order to account for residual transmit power in the stopbands and implementational tolerances.

The power emitted by the ATU-C is limited by the requirements in this clause. Notwithstanding these requirements, it is assumed that the ADSL will comply with applicable national requirements on emission of electromagnetic energy.

For spectrum management purposes, the PSD template nominal passband aggregate transmit power is 20.4 dBm.

I.1.3 ATU-C transmitter PSD mask for non-overlapped spectrum operation (supplements 8.10)

The ATU-C transmit spectral mask shall be identical to the ATU-C transmit spectral mask for non-overlapped spectrum operation over POTS, as defined in Figure A.2 in A.1.3, with the following modification:

- For $0 < f < 4$, the PSD shall be below -97.5 dBm/Hz (no extra limitation of max power in 0-4 kHz band).

Adherence to this mask will in many cases result in improved upstream performance of the other ADSL systems in the same or adjacent binder group, with the improvement dependent upon the other interferers. This mask differs from the mask in I.1.2 only in the band below 138 kHz.

The passband is defined as the band from 138 to 2208 kHz. Limits defined within the passband apply also to any narrower bands used.

The low-frequency stopband is defined as frequencies below 138 kHz; the high-frequency stopband is defined as frequencies greater than 2208 kHz.

I.1.3.1 Passband PSD and response

See A.1.3.1.

I.1.3.2 Aggregate transmit power

See A.1.3.2.

I.2 ATU-R functional characteristics (pertains to clause 8)

I.2.1 ATU-R control parameter settings

The ATU-R control parameter settings to be used in the parameterized parts of the main body of this Recommendation and/or to be used in this annex are listed in Table I.3. Control parameters are defined in 8.5.

Table I.3/G.992.5 – ATU-R control parameter settings

Parameter	Default setting	Characteristics
<i>NSC_{us}</i>	32	
<i>NOMPSD_{us}</i>	-38 dBm/Hz	Settings may be changed relative to this value during G.994.1 phase; see 8.13.2.
<i>MAXNOMPSD_{us}</i>	-38 dBm/Hz	Settings may be changed relative to this value during G.994.1 phase; see 8.13.2.
<i>MAXNOMATP_{us}</i>	13.3 dBm	Settings may be changed relative to this value during G.994.1 phase; see 8.13.2.

I.2.2 ATU-R upstream transmit spectral mask (supplements 8.10)

The passband is defined as the band from 3 to 138 kHz and is the widest possible band used. Limits defined within the passband apply also to any narrower bands used.

Figure I.2 defines the spectral mask for the transmit signal. The low-frequency stopband is defined as frequencies below 3 kHz, the high-frequency stopband is defined as frequencies greater than 138 kHz.

Figure I.2/G.992.5 – ATU-R transmitter PSD mask

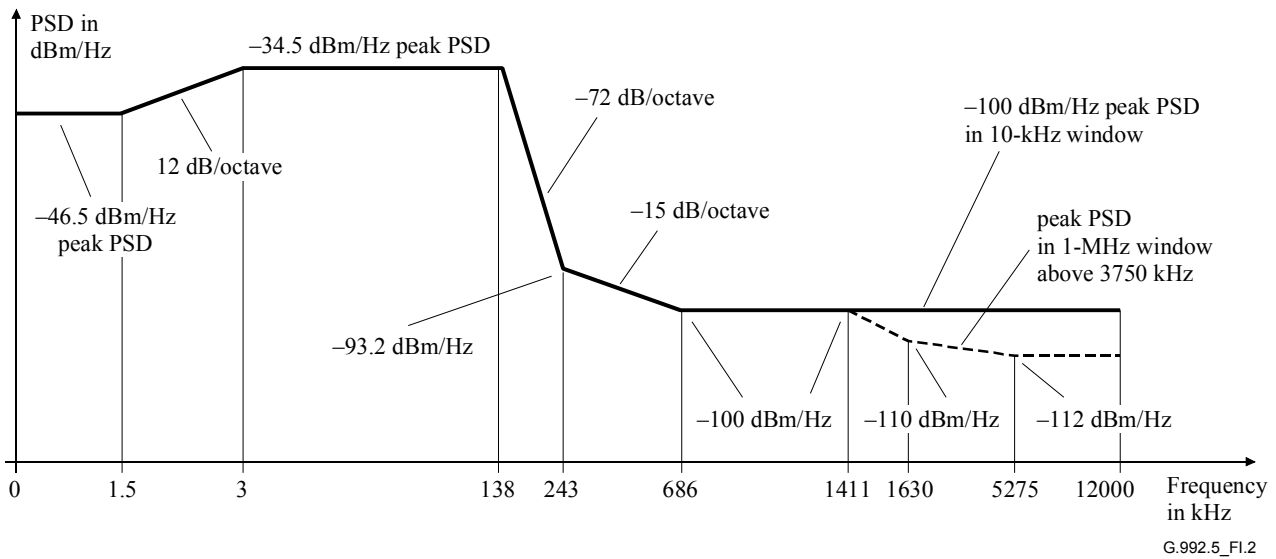

Frequency (kHz)	PSD level (dBm/Hz)	MBW
0	-46.5	100 Hz
1.5	-46.5	100 Hz
3	-34.5	100 Hz
10	-34.5	10 kHz
138	-34.5	10 kHz
243	-93.2	10 kHz
686	-100	10 kHz
5275	-100	10 kHz
12000	-100	10 kHz

Additionally, the PSD mask shall be satisfying following requirements:

Frequency (kHz)	PSD level (dBm/Hz)	MBW
1411	-100	1 MHz
1630	-110	1 MHz
5275	-112	1 MHz
12000	-112	1 MHz

NOTE 1 – All PSD measurements are in 100 Ω.

NOTE 2 – The breakpoint frequencies and PSD values are exact; the indicated slopes are approximate. The breakpoints in the tables shall be connected by linear straight lines on a dB/log(*f*) plot.

NOTE 3 – MBW specifies the measurement bandwidth. The MBW specified for a certain breakpoint with frequency *f_i* is applicable for all frequencies satisfying *f_i* < *f* ≤ *f_j*, where *f_j* is the frequency of the next specified breakpoint.

NOTE 4 – The power in a 1-MHz sliding window is measured in a 1-MHz bandwidth, starting at the measurement frequency, i.e., power in the [*f*, *f* + 1 MHz] window shall conform to the specification at frequency *f*.

NOTE 5 – All PSD and power measurements shall be made at the U-C interface.

1.2.2.1 Passband PSD and response

There are three different PSD masks for the ATU-R transmit signal, depending on the type of signal sent. Across the whole passband, the transmit PSD level shall not exceed the maximum passband PSD level, defined as:

- *NOMPSD_{us}* + 1 dB, for initialization signals up to and including the Channel Discovery Phase;
- *REFPSD_{us}* + 1 dB, during the remainder of initialization, starting with the Transceiver Training Phase;

- $MAXNOMPSD_{us} - PC_{Bus} + 3.5$ dB, during showtime.

The group delay variation over the passband shall not exceed 50 μ s.

The maximum transmit PSD level allows for 1 dB of non-ideal transmit filter effects (e.g., passband ripple and transition band rolloff).

For spectrum management purposes, the PSD template is defined in Table I.4 (informative):

Table I.4/G.992.5 – ATU-R transmitter PSD template

Frequency (kHz)	PSD level (dBm/Hz)
0	-50
1.5	-50
3	-38
138	-38
229.6	-92.9
686	-100
1411	-100
1630	-110
5275	-112
12000	-112

I.2.2.2 Aggregate transmit power

There are three different PSD masks for the ATU-R transmit signal, depending on the type of signal sent (see I.2.2.1). In all cases:

- the aggregate transmit power across the whole passband shall not exceed ($MAXNOMATP_{us} - PC_{Bus}$) by more than 0.5 dB, in order to accommodate implementational tolerances, and shall not exceed 13.8 dBm.
- the aggregate transmit power over the 0 to 12 MHz band shall not exceed ($MAXNOMATP_{us} - PC_{Bus}$) by more than 0.8 dB, in order to account for residual transmit power in the stopbands and implementational tolerances.

The power emitted by the ATU-R is limited by the requirements in this clause. Notwithstanding these requirements, it is assumed that the ADSL will comply with applicable national requirements on emission of electromagnetic energy.

For spectrum management purposes, the PSD template nominal passband aggregate transmit power is 13.3 dBm.

I.3 Initialization

For this annex, no additional requirements apply (relative to the main body of this Recommendation).

I.4 Electrical characteristics

See I.4/G.992.3.

The G.992.3 requirements applying over a frequency band up to 1104 kHz shall be met over a frequency band up to 2208 kHz.

Annex J

All Digital Mode ADSL with improved spectral compatibility with ADSL over ISDN

For further study.

Annex K

TPS-TC functional descriptions

See Annex K/G.992.3, with the following changes:

- 1) The G.994.1 codepoints shall represent the data rate divided by 8000 bit/s. The last row of Table K.6/G.992.3 shall show "8000 bit/s" instead of "4000 bit/s".
- 2) The ATU shall support a net data rate of at least 16 Mbit/s. *Net_min_n*, *Net_max_n* and *Net_reserve_n* entry in Table K.4/G.992.3, Table K.11/G.992.3 and Table K.20/G.992.3 shall show "16 Mbit/s" instead of "8 Mbit/s".

Annex L

Specific requirements for an ADSL system with extended upstream bandwidth, operating in the frequency band above POTS

For further study.

Appendix I

ATM Layer to Physical Layer logical interface

See Appendix I/G.992.3.

Appendix II

Compatibility with other customer premises equipment

See Appendix II/G.992.3.

Appendix III

The impact of primary protection devices on line balance

See Appendix III/G.992.3.

Appendix IV

PSD template to be used in capacity calculations with in-band transmit spectrum shaping

This appendix informs on the PSD template to be used in capacity calculations for cases where in-band transmit spectrum shaping (tss_i) is applied.

This Recommendation supports the possibility for downstream spectrum control with individual maximum transmit PSD at U-C reference point per subcarrier, under operator control through the CO-MIB (see 8.5.1), to allow configuration per the regional requirements (e.g., North America, Europe or Japan) and deployment scenarios (e.g., CO or Remote). The downstream spectrum is controlled via the control parameter $MIB_PSD_mask(f)$ (see 8.5.1). The parameter $MIB_PSD_mask(f)$ defines the PSD mask at the U-C reference point. The average PSD at the U-C reference point is given by $MIB_PSD_template(f)$ (see 8.5.1). The inband part of the CO-MIB specified PSD mask (part with the $MAXINSLOPE$) will typically be realized by adjusting the gain values of individual subcarriers using the tss_i (transmit spectrum shaping) values.

In capacity calculations, capacity depends on the transmit power on each individual subcarrier. This power is proportional to the squared tss_i value.

For a flat PSD template, the tss_i gain values are equal to 1 (assuming ideal flat time-domain filtering, DAC and AFE) and therefore the transmit power on each subcarrier can be directly calculated from the $MIB_PSD_template$.

However, it should be brought to attention that, if the inband part is non-flat shaped, it cannot be assumed that the tss_i gain values exactly follow the shape of the $MIB_PSD_template$. In other words, it cannot be assumed that the tss_i values equal the value $MIB_PSD_template(i) - NOMPSD$. This is because the side lobes of higher power subcarriers will increase the PSD of lower power carriers as measured at the U-C reference point.

For this reason, an equivalent PSD template shall be defined for the purpose of capacity calculations, incorporating the transmit spectrum shaping tss_i :

$$Capacity_PSD_template(i) = powergain_DAC\&AFE \times tss_i^2(i)$$

The tss_i values can be calculated using:

$$\begin{aligned} MIB_PSD_template_dB(f) &= MIB_PSD_mask_dB(f) - 3.5\text{ dB} \\ MIB_PSD_template(i) &= 10^{(MIB_PSD_template_dB(i, \Delta f)/10)} \\ &\text{for } n_IB_low_MIB \leq i \leq n_IB_high_MIB \\ tss_i^2 &= A^{-1} \times MIB_PSD_template/powergain_DAC\&AFE \end{aligned}$$

Alternatively, one can directly calculate:

$$Capacity_PSD_template(i) = A^{-1} \times MIB_PSD_template$$

where:

- tss_i^2 is the vector of the squared values of tss_i , i.e., $tss_i(i)^2$
- A^{-1} is the inverse of matrix A
- A is the matrix:

$$A(m, n) = \left(\frac{1}{K}\right) \times \frac{17}{16} \times \sin c\left(\frac{17}{16} \times (m - n)\right)^2$$

for $n_{IB_low_MIB} \leq m \leq n_{IB_high_MIB}$, $n_{IB_low_MIB} \leq n \leq n_{IB_high_MIB}$

$$\text{With } K = \sum \frac{17}{16} \times \sin c \left(\frac{17}{16} \times i \right)^2 = 1.1162 = 0.48 \text{ dB}$$

– $n_{IB_low_MIB}$ is the first tone of the inband part of the CO-MIB PSD mask.

Using the definitions in 8.5.1:

$$n_{IB_low_MIB} = t_1 \quad \text{if } t_1 = \text{roundup}(f_{pb_start}/\Delta f)$$

$$n_{IB_low_MIB} = t_2 \quad \text{if } 100 \leq t_1 \leq 256$$

– $n_{IB_high_MIB}$ is the last tone of the inband part of the CO-MIB PSD mask.

Using the definitions in 8.5.1:

$$n_{IB_high_MIB} = t_N$$

Capacity calculations should use the equivalent PSD template on each individual subcarrier as calculated by *Capacity_PSD_template*.

Appendix V

Bibliography

- [B1] ITU-T Recommendation G.995.1 (2001), *Overview of digital subscriber line (DSL) Recommendations*.

SERIES OF ITU-T RECOMMENDATIONS

Series A	Organization of the work of ITU-T
Series B	Means of expression: definitions, symbols, classification
Series C	General telecommunication statistics
Series D	General tariff principles
Series E	Overall network operation, telephone service, service operation and human factors
Series F	Non-telephone telecommunication services
Series G	Transmission systems and media, digital systems and networks
Series H	Audiovisual and multimedia systems
Series I	Integrated services digital network
Series J	Cable networks and transmission of television, sound programme and other multimedia signals
Series K	Protection against interference
Series L	Construction, installation and protection of cables and other elements of outside plant
Series M	TMN and network maintenance: international transmission systems, telephone circuits, telegraphy, facsimile and leased circuits
Series N	Maintenance: international sound programme and television transmission circuits
Series O	Specifications of measuring equipment
Series P	Telephone transmission quality, telephone installations, local line networks
Series Q	Switching and signalling
Series R	Telegraph transmission
Series S	Telegraph services terminal equipment
Series T	Terminals for telematic services
Series U	Telegraph switching
Series V	Data communication over the telephone network
Series X	Data networks and open system communications
Series Y	Global information infrastructure and Internet protocol aspects
Series Z	Languages and general software aspects for telecommunication systems